

Butterfly Valve, Metal

Construction

GEMÜ type D480 is a butterfly valve with various versions. It is available in nominal sizes DN 25 – 1600, various body versions (Wafer, Lug and U section) and in a large number of seal and body materials. It can be supplied with various operators: hand lever or gearbox, pneumatic actuator or motorized on/off or control actuator.

Features

- Suitable for gaseous and liquid media in industrial applications as well as water treatment
- Installation length acc. to ISO 5752/20, EN 558-1/20, API 609 category A
- Top flange acc. to EN ISO 5211
- Max. operating pressure 10/16/25 bar
- Connection standards: PN 10, PN 16, ASME B16.47 Series A Class 150, ASME B16.5 Class 150
- Valve acc. to EN 593
- Leak test acc. to EN 12266-1/P12 leakage rate A
- The butterfly valve complies with the safety requirements of Annex I of the European Pressure Equipment Directive 2014/34/EU for fluids of group 1 and 2



Sectional drawing

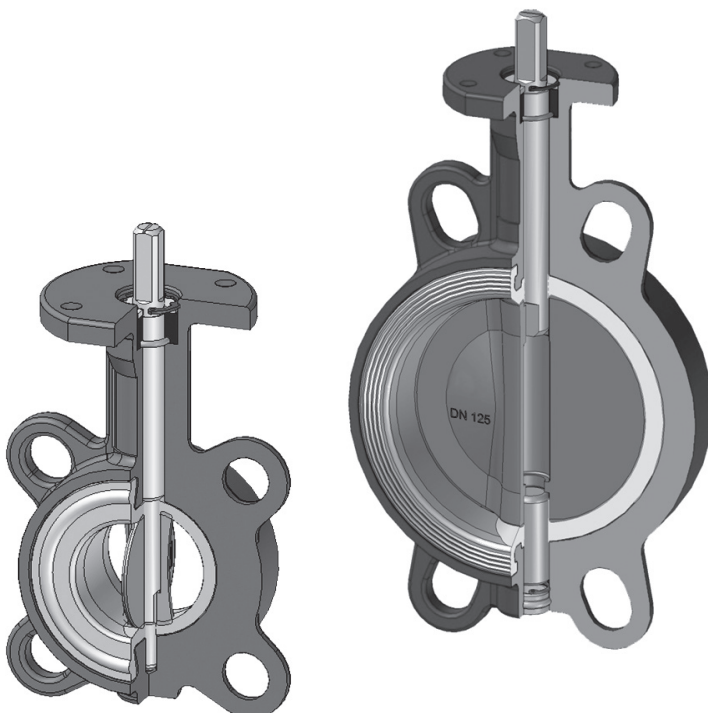

GEMÜ D480



GEMÜ D487



GEMÜ D481



GEMÜ D488

Technical data

Working medium

Gaseous and liquid media which have no negative impact on the physical and chemical properties of the disc and seal material.

Max. perm. temp. of working medium

-60 to 210 °C (dependent on seat (liner) material)

Other temperatures on request

No water hammer permissible

Ambient conditions

Max. permissible ambient temperature -20 to 70 °C

Vacuum

Loose liner:
can be used up to a vacuum of 800 mbar (abs)

Vulcanized liner :
can be used up to a vacuum of 2 mbar (abs)

This values are for room temperature and air. The values may deviate for other medias and other temperatures.

Kv values [m³/h]

DN	Opening angle							
	25°	30°	40°	50°	60°	70°	80°	90°
25/32	-	2	6	12	19	29	37	45
40	2,5	4,3	9	15	22	38	60	68
50	5,0	7,7	14	23	45	60	90	112
65	8,6	12,9	22	36	70	90	138	172
80	13	19	33	54	110	138	207	258
100	24	36	63	103	200	260	410	474
125	52	76	133	215	420	540	860	970
150	146	125	215	353	690	890	1420	1680
200	146	215	360	603	1120	1510	2350	2800
250	224	336	580	990	1850	3190	3700	4310
300	327	475	860	1380	2670	3490	5215	6465
350	430	645	1120	1896	3535	4395	6980	8620
400	560	775	1465	2285	4395	5600	9310	10775
450	775	1077	1980	3190	6120	7930	12700	15086
500	970	1380	2415	3965	7500	9900	15085	18965
600	1293	1895	3275	8260	10130	14225	20700	24137
700	1350	1990	3860	5980	10600	17100	25300	36000
750	1560	2125	4350	7150	11450	18400	27400	40500
800	1600	2200	4500	8200	12500	20000	29000	44000
900	1800	2300	6100	10400	17500	29000	42000	58000
1000	2500	3800	8700	13500	23000	37500	59200	80500
1200	5400	7800	12500	22600	35500	61500	82000	110500
1400	5680	8568	15256	28950	45685	85700	145800	170500
1600	6456	10952	20568	37850	59452	110325	198450	220350

The specified Kv values refer to the design without encapsulated disc.

For the design with encapsulated disc (material code F), the Kv value is reduced by approx. 30 %.

Technical data

Torques dependent on the material combination [Nm]

Material (code)		Operating pressure	Nominal size											
Disc	Seat (liner)		PS	DN										
		25/32		40	50	65	80	100	125	150	200	250	300	350
A, B, D, E, G, H, K	E, N	3 bar	5	5	5	15	17	22	39	48	90	126	161	245
		6 bar	6	6	7	16	20	29	46	75	120	210	270	300
		10 bar	9	9	13	20	23	42	72	90	140	270	390	500
		16 bar	15	15	17	25	28	50	85	110	215	350	560	950
	A, C, D, F, G, H, J, K, O, P, R, S, V, W, Z	3 bar	6	6	6	18	20	26	47	58	108	151	193	294
		6 bar	7	7	8	19	24	35	55	90	144	252	324	360
		10 bar	11	11	16	24	28	50	86	108	168	324	468	600
		16 bar	18	18	20	30	34	60	102	132	258	420	672	1140
C, F, N, P, R	E, N	3 bar	6	6	6	18	20	26	47	58	108	151	193	294
		6 bar	7	7	8	19	24	35	55	90	144	252	324	360
		10 bar	11	11	16	24	28	50	86	108	168	324	468	600
		16 bar	18	18	20	30	34	60	102	132	258	420	672	1140
	A, C, D, F, G, H, J, K, O, P, R, S, V, W, Z	3 bar	7	7	7	22	24	32	56	69	130	181	232	353
		6 bar	9	9	10	23	29	42	66	108	173	302	389	432
		10 bar	13	13	19	29	33	60	104	130	202	389	562	720
		16 bar	22	22	24	36	40	72	122	158	310	504	806	1368

Material (code)		Operating pressure	Nominal size											
Disc	Seat (liner)		PS	DN										
		400		450	500	600	700	750	800	900	1000	1200	1400	1600
A, B, D, E, G, H, K	E, N	3 bar	520	590	840	1000	1650	1800	2300	4700	6500	8500	14000	22000
		6 bar	600	1120	1390	2200	3300	3500	4600	6800	8500	12000	17000	26000
		10 bar	700	1450	1800	3450	5000	5500	6500	8500	11500	15500	19500	30000
		16 bar	1000	1950	2500	3800	5860	6000	9500	11500	15000	22000	-	-
	A, C, D, F, G, H, J, K, O, P, R, S, V, W, Z	3 bar	624	708	1008	1200	1980	2160	2760	5640	7800	10200	16800	26400
		6 bar	720	1344	1668	2640	3960	4200	5520	8160	10200	14400	20400	31200
		10 bar	840	1740	2160	4140	6000	6000	7800	10200	13800	18600	23400	36000
		16 bar	1200	2340	3000	4560	7032	7200	11400	13800	18000	26400	-	-
C, F, N, P, R	E, N	3 bar	624	708	1008	1200	1980	2160	2760	5640	7800	10200	16800	26400
		6 bar	720	1344	1668	2640	3960	4200	5520	8160	10200	14400	20400	31200
		10 bar	840	1740	2160	4140	6000	6000	7800	10200	13800	18600	23400	36000
		16 bar	1200	2340	3000	4560	7032	7200	11400	13800	18000	26400	-	-
	A, C, D, F, G, H, J, K, O, P, R, S, V, W, Z	3 bar	749	850	1210	1440	2376	2592	3312	6768	9360	12240	20160	31680
		6 bar	864	1613	2002	3168	4752	5040	6624	9792	12240	17280	24480	37440
		10 bar	1008	2088	2592	4968	7200	7200	9360	12240	16560	22320	28080	43200
		16 bar	1440	2808	3600	5472	8438	8640	13680	16560	21600	31680	-	-

Torques dependent on the material combination [Nm]

Torque values valid for optimal operating conditions, 20 °C, lubricious liquids

Order data

1 Type	Code
Butterfly valve with bare shaft	D480
Butterfly valve with pneumatic actuator	D481
Butterfly valve with manual operator	D487
Butterfly valve with motorized actuator	D488

2 Nominal size	Code
DN 25	25
DN 32	32
DN 40	40
DN 50	50
DN 65	65
DN 80	80
DN 100	100
DN 125	125
DN 150	150
DN 200	200
DN 250	250
DN 300	300
DN 350	350
DN 400	400
DN 450	450
DN 500	500
DN 600	600
DN 700	700
DN 750	750
DN 800	800
DN 900	900
DN 1000	1T0
DN 1200	1T2
DN 1400	1T4
DN 1600	1T6

3 Body configuration	Code
Wafer (DN 25 - 1200)	W
Lug (DN 25 - 1000)	L
U section (DN 200 - 1600)	U

4 Operating pressure				
DN	PS 3bar	PS 6bar	PS 10bar	PS 16bar
	Code			
25	0	1	2	3
32	0	1	2	3
40	0	1	2	3
50	0	1	2	3
65	0	1	2	3
80	0	1	2	3
100	0	1	2	3
125	0	1	2	3
150	0	1	2	3

4 Operating pressure				
DN	PS 3bar	PS 6bar	PS 10bar	PS 16bar
	Code			
200	0	1	2	3
250	0	1	2	3
300	0	1	2	3
350	0	1	2	3
400	0	1	2	3
450	0	1	2	3
500	0	1	2	3
600	0	1	2	3
700	0	1	2	3
750	0	1	2	3
800	0	1	2	3
900	0	1	2	3
1000	0	1	2	3
1200	0	1	2	3
1400	0	1	2	
1600	0	1	2	

Standard PS 25 on request

5 Connection							
DN	Wafer			Lug		U section	
	PN 6	PN 10	PN 16	PN 10	PN 16	PN 10	PN 16
	Code			Code		Code	
25	3	3	3	3	3		
32	3	3	3	3	3		
40	3	3	3	3	3		
50		3	3	3	3		
65	3	3	3	3	3		
80	3	3	3	3	3		
100	3	3	3	3	3		
125	3	3	3	3	3		
150	3	3	3	3	3	2	3
200	3	3	3	2	3	2	3
250	3	3	3	2	3	2	3
300	3	3	3	2	3	2	3
350		3	3	2	3	2	3
400		3	3	2	3	2	3
450		2	3	2	3	2	3
500		2	3	2	3	2	3
600		2	3	2	3	2	3
700		2	3	2	3	2	3
750		2	3	2	3	2	3
800		2	3	2	3	2	3
900		2	3	2	3	2	3
1000		2	3	2	3	2	3
1200		2	3			2	3
1400						2	3
1600						2	3

Standard
For further connections see availability on page 12

Order data

6 Body material	Code
EN-GJS-400-15 (GGG 40), Epoxy coated, DN 25 - 600	2
EN-GJL-250 (GG 25), Epoxy coated, DN 700 - 1600	1
EN-GJS-400-18-LT (GGG 40.3), Epoxy coated, DN 25 - 300, body configuration Lug	3
ASTM A351, CF8M, cast stainless steel 1.4408	4
ASTM A216 WCB, cast steel	5
S 275 JR + Epox laminated carbon steel	9
EN-AC-46100 / EN-AC-47100, cast aluminium	0

7 Disc material	Code
CF8M, 1.4408	A
CF8M, 1.4408 polished	B
EN-GJS-400-15 (GGG 40), Halar coated	P
CF8M, 1.4408 Halar coated	C
1.4469 Super Duplex	D
EN-GJS-400-15 / GGG40, Epoxy coated (Resicoat)	E
EN-GJS-400-15 / GGG40, rubber lined EPDM (≤ DN 600)	F
EN-GJS-400-15 (GGG 40) (≤ DN 600) rubber lined Flucast AB/P	N
EN-GJS-400-15, GGG40 Rilsan® PA11 coated (≤ DN 600)	R
Cast bronze: DIN 1705 (Rg 10) (≤ DN 300), UNE EN 1982 (CuAl10FeNi5C) (≥ DN 350)	G
URANUS B6, 1.4539 (similar 904L)	K
2.4602, Alloy 22 (NiCr21Mo14W) (≤ DN 200)	H

8 Shaft material	Code
AISI 420 / 1.4021	1
AISI 316 / 1.4401 (max. operating pressure PS 10 bar)	2
1.4462 Duplex	4

9 Seat (liner) material	Code
EPDM -20...+ 110 °C	E
EPDM KP / FDA (not vulcanizable) -10...+ 130 °C	Z
EPDM (ACS, WRAS, DVGW water approval) -20...+ 95 °C	W
NBR LT -20...+ 90 °C	2
NBR -10...+ 90 °C	N
NBR (DVGW Gas) -10...+ 90 °C	J
HNBR -10 ...+100 °C	A
FKM -15 ...+210 °C	V
FKM GF -15 ...+210 °C	D
FKM - BIO -5 ...+200 °C	O
AB/P - SBR (abrasion-resistant) -10 ...+ 70 °C	F
AB/E - EPDM (abrasion-resistant) -10 ...+ 90 °C	G

9 Seat (liner) material	Code
AB/E - EPDM (abrasion-resistant) -10 ... + 90 °C	G
AB/N - NBR (abrasion-resistant) 0 ... + 90 °C	K
AB/T - EPDM-HT (abrasion-resistant) -5 ... +130 °C	B
Silicone (steam) (red. operating press. max. 10 bar) -60 ... +140 °C	R
Silicone -60 ... +200 °C	S
Hypalon -25 ... +120 °C	H
Epichlorhydrine -40 ... +125 °C	C
Neoprene -25 ... + 80 °C	P

10 Liner fixing	Code
Loose liner (standard)	L
Bonded liner (to DN 400)	B
Vulcanized liner (to DN 1000)	V

11 Control function	Code
Butterfly valve with bare shaft type D480	F
Butterfly valve with manual operator type D487	0
Normally closed (NC) type D481	1
Normally open (NO) type D481	2
Double acting (DA) type D481	3
Normally closed (NC), actuator mounted across the piping type D481	Q
Double acting (DA) actuator mounted across the piping type D481	T
Normally open (NO), actuator mounted across the piping type D481	U

12 Special function	Code
ACS	A*
DVGW water	D*
WRAS	W*

* only seat (liner) material Code W

13 Operator size	Code
D480 (column 12)	see page 13
D481 (column 12)	see page 17
D487 (column 12)	see page 14/15
D488 (column 13/14/15)	see page 22

Order example	1	2	3	4	5	6	7	8	9	10	11	12	13
Code	D480	50	W	3	3	2	A	1	E	L	F	-	07 D11

Other designs and materials on request

Parts list

* not body material- cast aluminium (code 0)

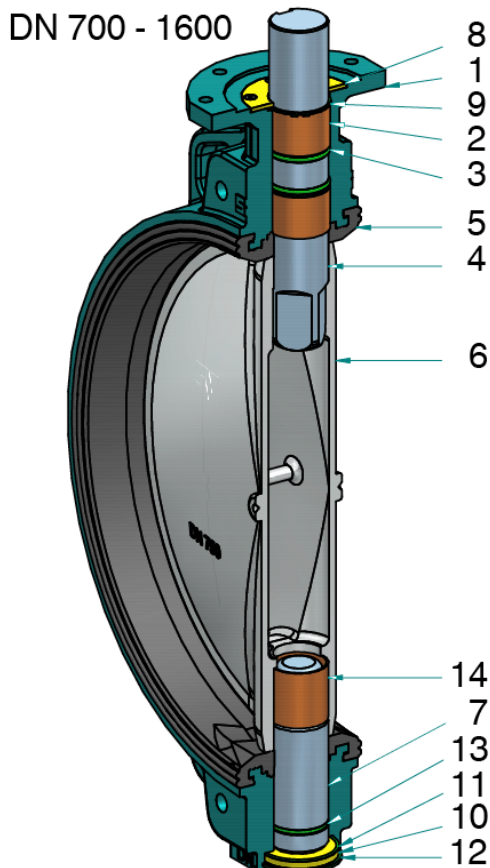
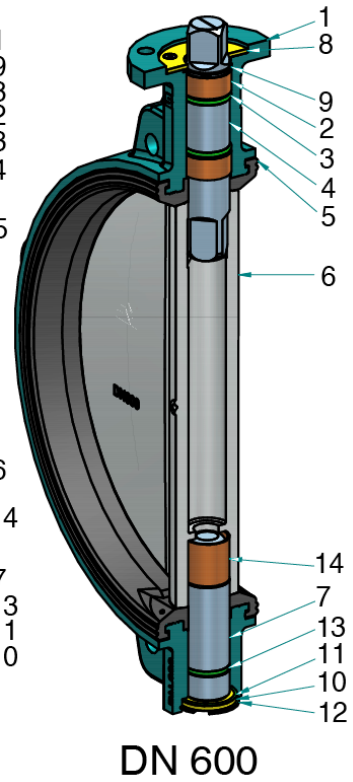
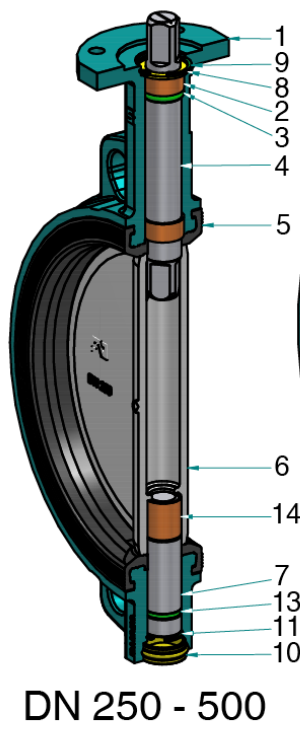
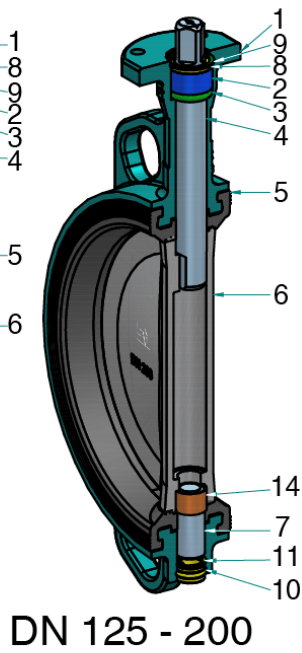
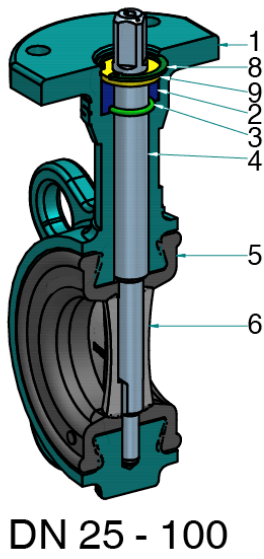

Pos.	Bearing
1	Body
2	Bearing
3	O-ring
4	Shaft
5	Seat (liner)
6	Disc
7	Lower axis
8	Circlip
9	Washer
10	Plug
11	Circlip
12	O-ring
13	O-ring
14	Bearing

Body dimensions [mm]

Body configuration - Wafer (code W)

DN	A	B	C	D	D1	E	G	øa	H	J	K	L	ISO	P	Q	R	S	T	Weight [kg]
25	102.5	60.2	33	68	-	18	□11	90	15	100.0	85.0	8	F07	13.0	70	4x9	-	-	1.5
32	102.5	60.2	33	68	-	18	□11	90	15	100.0	85.0	8	F07	13.0	70	4x9	-	-	1.5
40	110.0	56.0	33	76	-	18	□11	90	26	110.0	95.0	10	F07	13.0	70	4x9	-	-	1.7
50	120.0	61.5	43	100	-	18	□11	90	30	125.0	120.6	10	F07	13.0	70	4x9	-	-	2.4
65	135.0	69.0	46	108	-	18	□11	90	47	145.0	127.0	10	F07	13.0	70	4x9	-	-	2.7
80	141.0	94.0	46	124	-	18	□11	90	66	160.0	145.0	10	F07	13.0	70	4x9	-	-	3.2
100	165.0	106.0	52	147	-	18	□11	90	90	185.5	165.0	10	F07	13.0	70	4x9	-	-	4.0
125	180.0	126.5	56	180	-	18	□14	90	113	225.0	206.0	12	F07	17.0	70	4x9	-	-	6.2
150	193.0	133.0	56	206	-	18	□14	90	139	241.3	229.0	12	F07	17.0	70	4x9	-	-	7.3
200	225.0	170.0	60	257	-	24	□17	90	193	305.0	280.0	12	F07	20.3	70	4x9	-	-	11.1
250	282.5	210.0	68	324	-	32	□22	130	241	362.0	335.0	14	F10	26.2	102	4x12	3	70	20.2
300	308.0	240.0	78	376	-	32	□22	130	290	431.8	394.0	14	F10	26.2	102	4x12	3	70	29.6
350	338.5	263.0	78	430	-	32	□22	160	338	476.3	445.0	15	F10	28.0	102	4x12	3	70	35.2
400	380.0	308.0	102	485	-	28	□27	160	387	540.0	510.0	18	F12	33.0	125	4x14	4	85	55.5
450	380.5	340.0	114	536	-	37	□36	190	437	-	-	20	F14	48.0	140	4x18	4	100	79.7
500	432.5	380.0	127	593	722	37	□36	210	478	-	-	20	F14	48.0	140	4x18	4	100	114.0
600	494.0	440.0	154	690	848	47	□46	210	578	-	-	24	F16	-	165	4x22	5	130	170.9
700	590.0	490.0	165	830	911	106	Ø65	300	678	-	-	30	F25	-	254	8x18	5	200	252.9
750	590.0	530.0	190	836	-	106	Ø80	300	703	-	-	25	F25	-	254	8x18	5	200	294.9
800	630.0	565.0	190	902	-	106	Ø80	300	767	-	-	28	F25	-	254	8x18	5	200	346.5
900	695.0	610.0	203	1010	-	110	Ø80	350	867	-	-	32	F25	-	254	8x18	5	200	459.5
1000	770.0	675.0	216	1116	-	110	Ø80	350	964	-	-	32	F25	-	254	8x18	5	200	580.7
1200	875.0	818.0	254	1334	-	110	Ø100	350	1158	-	-	40	F30	-	298	8x23	5	230	963.3

DN 500 - 700

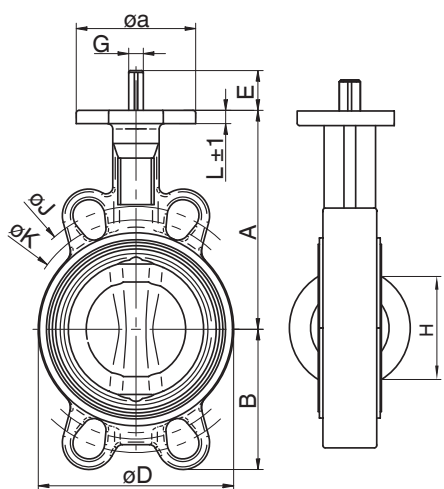

DN 32-450

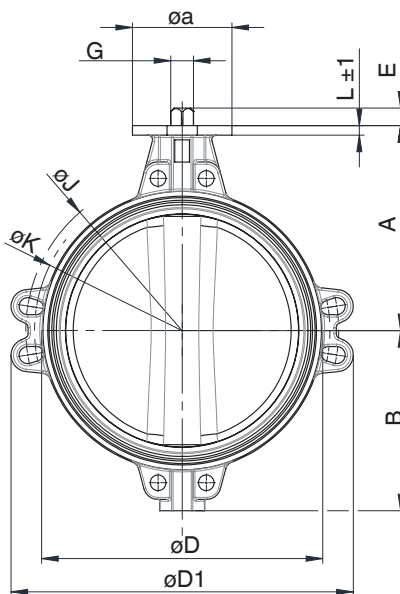
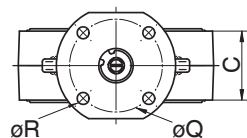

Shaft connection, square diagonal
DN 25 - 600

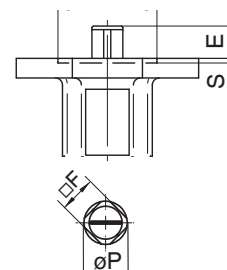

Shaft connection, round with single keyway
DN 700 - 1200

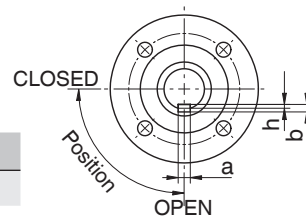
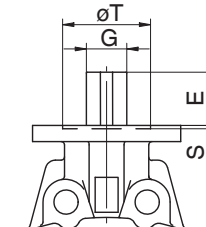

DN	a	b	h
700	18	11	7
750-1100	22	14	9
1200	28	16	10

Body dimensions [mm]

Body configuration - Lug (code L)

DN	A	B	C	D	E	G	øa	H	J	L	ISO	P	Q	R	S	T	Weight [kg]
25	102.5	50.4	33	68	18	□11	90	15	130	8	F07	13.0	70	4x9			1.9
32	102.5	50.4	33	68	18	□11	90	15	130	8	F07	13.0	70	4x9			1.9
40	110.0	54.0	33	76	18	□11	90	26	140	10	F07	13.0	70	4x9			2.0
50	120.0	59.5	43	100	18	□11	90	30	156	10	F07	13.0	70	4x9			2.9
65	135.0	66.5	46	108	18	□11	90	47	175	10	F07	13.0	70	4x9			3.3
80	141.0	91.0	46	124	18	□11	90	66	194 185	10	F07	13.0	70	4x9			4.8 3.5
100	165.0	105.0	52	147	18	□11	90	90	224	10	F07	13.0	70	4x9			6.3
125	180.0	125.0	56	180	18	□14	90	113	267	12	F07	17.0	70	4x9			9.8
150	193.0	136.5	56	206	18	□14	90	139	292	12	F07	17.0	70	4x9			10.6
200	225.0	156.0 171.0	60	257	24	□17	90	193	334 352	12	F07	20.3	70	4x9			13.4 17.5
250	282.5	210.0	68	324	32	□22	130	241	409	14	F10	26.2	102	4x12	3	70	26.4
300	308.0	240.0	78	376	32	□22	130	290	480	14	F10	26.2	102	4x12	3	70	39.6
350	338.5	263.0	78	430	32	□22	160	338	522	18	F10	28.0	102	4x12	3	70	56.1
400	380.0	308.0	102	485	28	□27	160	387	595	17	F12	33.0	125	4x14	4	85	74.9
450	380.5	340.0	114	536	37	□36	190	437	633 638	20	F14	48.0	140	4x18	4	100	103.0 94.6
500	432.5	380.0	127	593	37	□36	210	478	717	20	F14	48.0	140	4x18	4	100	158.0
600	494.0	440.0	154	690	47	□46	210	578	833	24	F16		165	4x22	5	130	220.0
700	590.0	490.0	165	832	106	Ø65	300	678	904 924	30	F25		254	8x18	5	200	293.0 312.0
750	590.0	530.0	190	836	106	Ø80	300	703	964 979	25	F25		254	8x18	5	200	373.0 392.0
800	630.0	565.0	190	902	106	Ø80	300	767	1020	28	F25		254	8x18	5	200	432.0
900	695.0	610.0	203	1010	110	Ø80	350	867	1120	32	F25		254	8x18	5	200	539.0
1000	770.0	675.0	216	1116	110	Ø80	350	964	1246	32	F25		254	8x18	5	200	690.0

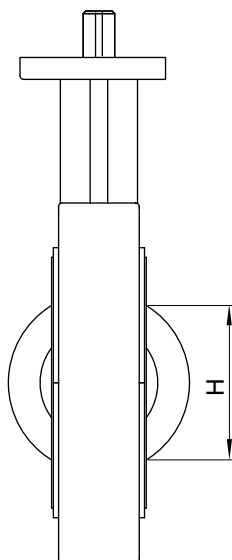
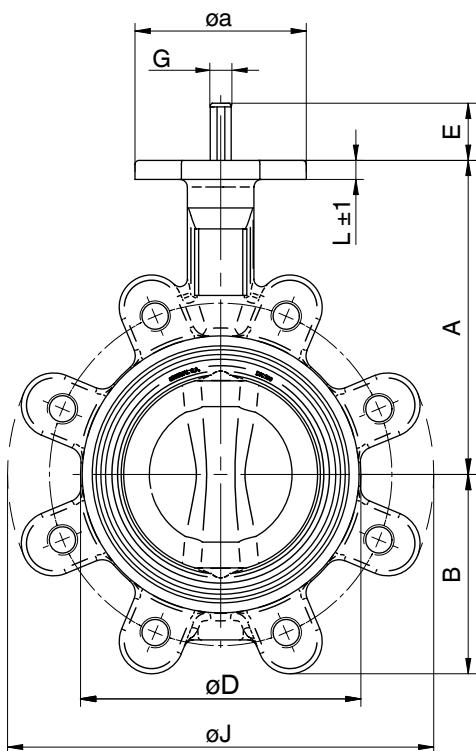

Shaft connection
Square, diagonal
DN 25 - 600

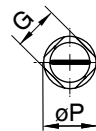
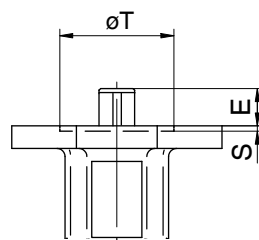

Shaft connection
Round with single keyway
DN 700 - 1000

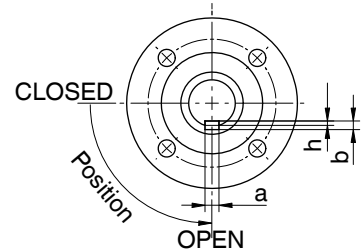
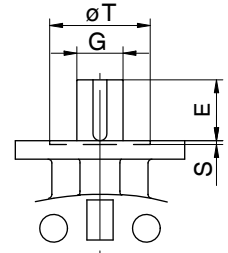

DN	a	b	h
700	18	11	7
750-1000	22	14	9

Body dimensions [mm]

Body configuration - U section (code U)

DN	A	B	C	D	E	G	øa	H	L	ISO	P	Q	R	S	T	Weight [kg]
150	193.0	143.0	56	285	19	□14	90	139	12	F07	17.0	70	4x9			11.0
200	225.0	172.5	60	345	24	□17	90	193	12	F07	20.3	70	4x9			18.4
250	282.5	210.0	68	406	32	□22	130	241	14	F10	26.2	102	4x12	3	70	30.8
300	308.0	240.0	78	480	32	□22	130	290	14	F10	26.2	102	4x12	3	70	45.4
350	338.5	268.0	78	535	32	□22	160	338	15	F10	28.0	102	4x12	3	70	54.4
400	380.0	308.0	102	597	28	□27	160	387	18	F12	33.0	125	4x14	4	85	79.2
450	380.5	340.0	114	640	37	□36	190	437	20	F14	48.0	140	4x18	4	100	99.9
500	432.5	380.0	127	700	37	□36	210	478	20	F14	48.0	140	4x18	4	100	134.5
600	494.0	440.0	154	834	47	□46	210	578	24	F16		165	4x22	5	130	216.4
700	590.0	490.0	165	916	106	Ø65	300	678	30	F25		254	8x18	5	200	273.9
750	590.0	530.0	190	995	106	Ø80	300	703	25	F25		254	8x18	5	200	348.9
800	630.0	565.0	190	1065	106	Ø80	300	767	28	F25		254	8x18	5	200	395.5
900	695.0	610.0	203	1120	110	Ø80	350	867	32	F25		254	8x18	5	200	511.5
1000	770.0	675.0	216	1290	110	Ø80	350	964	32	F25		254	8x18	5	200	704.7
1200	875.0	818.0	254	1485	120	Ø100	350	1158	40	F30		298	8x23	5	230	1094.0
1400	1000.0	969.0	280	1685	120	Ø120	350	1339	35	F30		298	8x23	5	230	1656.0
1600	1115.0	1090.0	318	1930	160	Ø130	475	1533	40	F40		406	8x39	8	300	2132.0

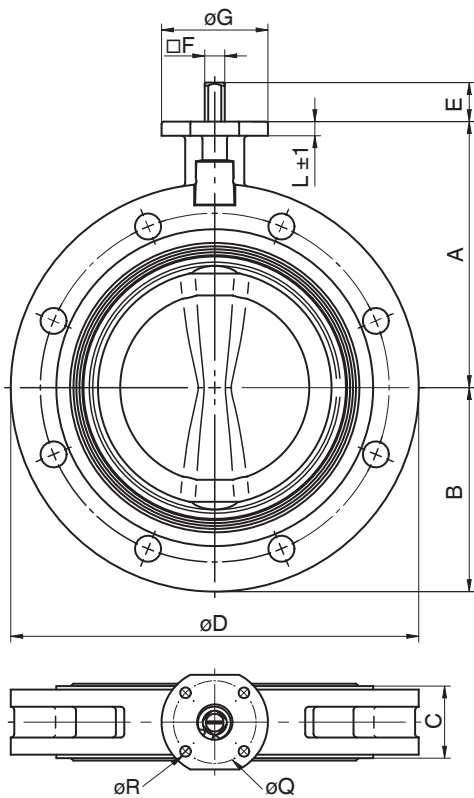

Shaft connection
Square, diagonal
DN 25 - 600

Shaft connection
Round with single keyway
DN 700 - 1600

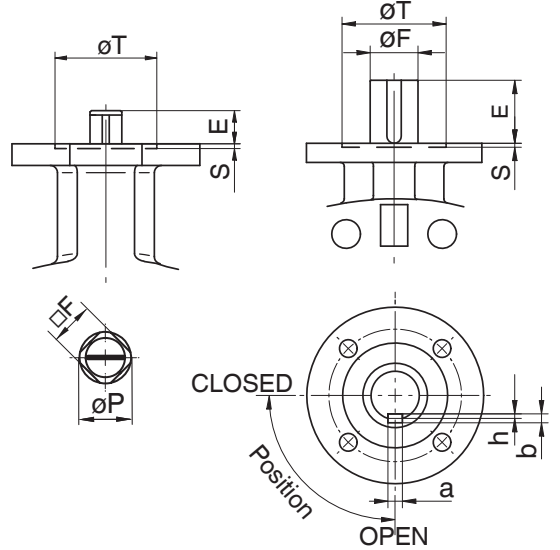

DN	a	b	h
700	18	11	7
750-1100	22	14	9
1200	28	16	10
1400, 1600	32	18	11

Connection dimensions [mm]

Wafer (Code W)

DN	E	PN 10						PN 16						ASME Class 150*					
		øD	e	L	L1	n	G	øD	e	L	L1	n	G	øD	e	L	L1	n	G
25	33	85	16	90	110	4	M12	85	16	90	110	4	M12	79.4	14.3	85	105	4	1/2"-13 UNC
32	33	100	16	90	110	4	M16	100	16	90	110	4	M16	88.9	17.5	90	110	4	1/2"-13 UNC
40	33	110	16	90	110	4	M16	110	16	90	110	4	M16	98.4	17.5	90	110	4	1/2"-13 UNC
50	43	125	18	100	120	4	M16	125	18	100	120	4	M16	120.6	19.0	100	120	4	5/8"-11 UNC
65	46	145	18	100	120	4	M16	145	18	100	120	4	M16	139.7	22.2	110	130	4	5/8"-11 UNC
80	46	160	20	110	130	8	M16	160	20	110	130	8	M16	152.4	23.8	110	130	4	5/8"-11 UNC
100	52	180	20	110	130	8	M16	180	20	110	130	8	M16	190.5	23.8	120	140	8	5/8"-11 UNC
125	56	210	22	120	140	8	M16	210	22	120	140	8	M16	215.9	23.8	130	150	8	3/4"-10 UNC
150	56	240	22	130	150	8	M20	240	22	130	150	8	M20	241.3	25.4	130	150	8	3/4"-10 UNC
200	60	295	24	130	160	8	M20	295	24	130	160	12	M20	298.5	28.6	140	160	8	3/4"-10 UNC
250	68	350	26	150	170	12	M20	355	26	150	170	12	M24	361.9	30.2	160	180	12	7/8"- 9 UNC
300	78	400	26	160	180	12	M20	410	28	160	180	12	M24	431.8	31.7	170	190	12	7/8"- 9 UNC
350	78	460	26	170	180	16	M20	470	30	170	190	16	M24	476.2	34.9	180	200	12	1"- 8 UNC
400	102	515	26	180	210	16	M24	525	32	200	220	16	M27	539.7	36.5	210	230	16	1"- 8 UNC
450	114	585	26	190	220	16	M24	585	32	210	240	16	M27	577.8	39.7	230	250	16	1 1/8"-7 UNC
			60	220	20	8				60	240	8							
500	127	620	28	210	230	20	M24	650	34	230	260	20	M30	635.0	46.0	250	280	20	1 1/8"-7 UNC
600	154	725	28	240	270	20	M24	770	36	260	290	20	M33	749.3	47.6	280	310	20	1 1/4"-7 UNC
700	165	840	30	260	280	20	M27	840	36	270	300	20	M33	863.5	52.5	310	340	24	1 1/4"-7 UNC
			80	280	8					85	300	8				110	340	8	
750	190	900	32	290	320	20	M30	900	38	300	345	20	M33	914.4	54.0	335	375	24	1 1/4"-7 UNC
			95	320	8					100	345	8				110	375	8	
800	190	950	32	290	320	20	M30	950	38	310	345	20	M36	978.0	57.0	340	380	24	1 1/2"-6 UNC
			110	320	8					100	345	8				95	380	8	
900	203	1050	34	310	350	24	M30	1050	40	330	375	24	M36	1086.0	60.0	370	415	28	1 1/2"-6 UNC
			100	350	8					100	375	8				110	415	8	
1000	216	1160	34	325	360	24	M33	1170	42	345	390	24	M39	1200.0	63.5	390	430	32	1 1/2"-6 UNC
			95	360	8					100	390	8				120	430	8	
1100	216	1270	38	330	370	28	M33	1270	48	360	400	28	M39	1314.5	101.0	465	410	36	1 1/2"-6 UNC
			100	370	8					110	400	8				150	410	8	
1200	254	1380	38	375	420	28	M36	1390	48	395	445	28	M45	1422.0	108.0	475	520	40	1 1/2"-6 UNC
			110	420	8					115	445	8				165	520	8	

* DN 25 - 600: ASME B16.5; DN 700 - 1200: ASME B16.47 Series A

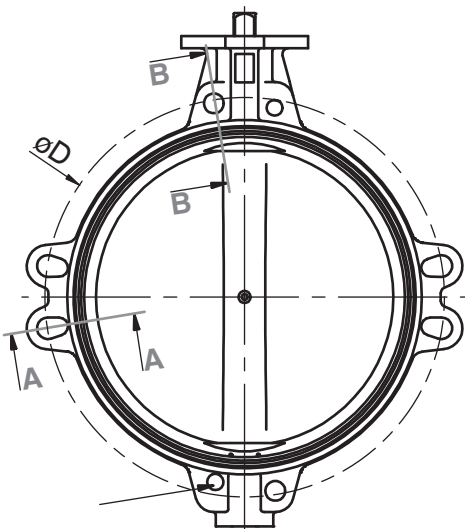

Flange holes are specially machined
(finish as threaded holes)
DN 450, DN 700 - 1200

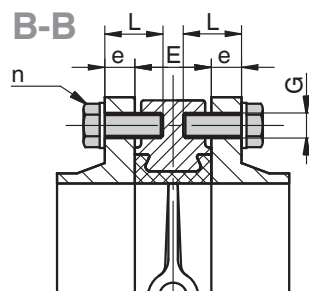
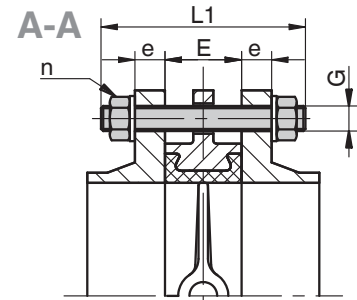
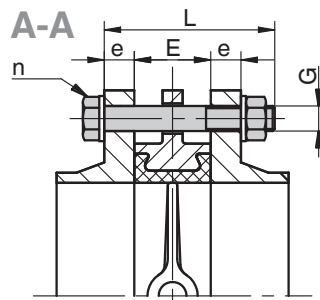

n = number of screws

Connection dimensions [mm]

Lug (Code L)

DN	E	PN 10					PN 16					ASME B16.5 Class 150				
		øD	e	L	n	G	øD	e	L	n	G	øD	e	L	n	G
25	33	85	16	30	8	M12	85	16	30	8	M12	79.4	14.3	30	8	1/2"-13 UNC
32	33	100	16	30	8	M16	100	16	30	8	M16	88.9	17.5	30	8	1/2"-13 UNC
40	33	110	16	30	8	M16	110	16	30	8	M16	98.4	17.5	30	8	1/2"-13 UNC
50	43	125	18	35	8	M16	125	18	35	8	M16	120.6	19.0	35	8	5/8"-11 UNC
65	46	145	18	40	8	M16	145	18	40	8	M16	139.7	22.2	45	8	5/8"-11 UNC
80	46	160	20	40	16	M16	160	20	40	16	M16	152.4	23.8	45	8	5/8"-11 UNC
100	52	180	20	45	16	M16	180	20	45	16	M16	190.5	23.8	45	16	5/8"-11 UNC
125	56	210	22	50	16	M16	210	22	50	16	M16	215.9	23.8	50	16	3/4"-10 UNC
150	56	240	22	50	16	M20	240	22	50	16	M20	241.3	25.4	50	16	3/4"-10 UNC
200	60	295	24	50	16	M20	295	24	50	24	M20	298.5	28.6	55	16	3/4"-10 UNC
250	68	350	26	60	24	M20	355	26	60	24	M24	361.9	30.2	60	24	7/8"- 9 UNC
300	78	400	26	65	24	M20	410	28	65	24	M24	431.8	31.7	70	24	7/8"- 9 UNC
350	78	460	26	65	32	M20	470	30	65	32	M24	476.2	34.9	70	24	1"- 8 UNC
400	102	515	26	75	32	M24	525	32	80	32	M27	539.7	36.5	85	32	1"- 8 UNC
450	114	565	26	75	32	M24	585	32	80	32	M27	577.8	39.5	85	32	1 1/8"- 7 UNC
				60	8				60	8						
500	127	620	28	90	40	M24	650	34	65	40	M30	635.0	46.0	105	40	1 1/8"- 7 UNC
600	154	725	28	100	40	M27	770	36	110	40	M33	749.3	47.6	120	40	1 1/4"- 7 UNC
700	165	840	30	110	40	M27	840	36	120	40	M33	863,5	-	-	-	-
				80	8				85	8						
750	190	900	32	130	40	M30	900	38	130	40	M33	914.4	54.0	150	48	1 1/4"- 7 UNC
				100	8				100	8				110	8	
800	190	950	32	130	40	M30	950	38	130	40	M36	-	-	-	-	-
				110	8				110	8						
900	203	1050	34	130	48	M30	1050	40	140	48	M36	-	-	-	-	-
				95	8				100	8						
1000	216	1160	34	140	48	M33	1170	42	150	48	M39	-	-	-	-	-
				95	8				100	8						

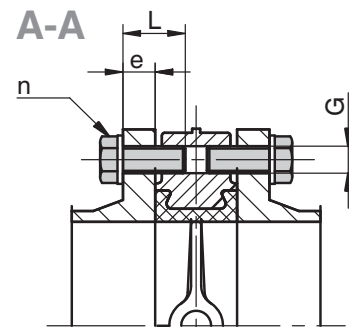
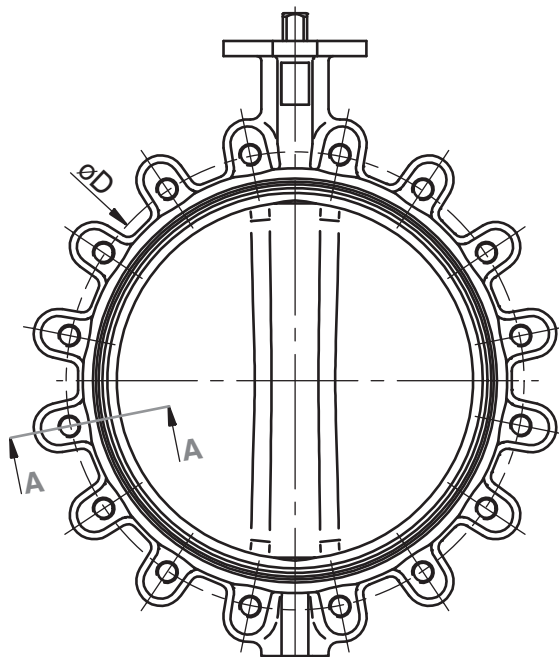

n = number of screws

Connection dimensions [mm]

U section (Code U)

DN	E	PN 10						PN 16						ASME Class 150*					
		øD	e	L	L1	n	G	øD	e	L	L1	n	G	øD	e	L	L1	n	G
150	56	240	22	130	150	8	M20	240	22	130	150	8	M20	241.3	25.4	130	150	8	3/4"-10 UNC
200	60	295	24	130	160	8	M20	295	24	130	160	12	M20	298.5	28.6	140	160	8	3/4"-10 UNC
250	68	350	26	150	170	12	M20	355	26	150	170	12	M24	361.9	30.2	160	180	12	7/8"- 9 UNC
300	78	400	26	160	180	12	M20	410	28	160	180	12	M24	431.8	31.7	170	190	12	7/8"- 9 UNC
350	78	460	26	170	180	16	M20	470	30	170	190	16	M24	476.2	34.9	180	200	12	1"- 8 UNC
400	102	515	26	180	210	16	M24	525	32	200	220	16	M27	539.7	36.5	210	230	16	1"- 8 UNC
450	114	565	26	190	220	16	M24	585	32	210	240	16	M27	577.8	39.7	230	250	16	1 1/8"-7 UNC
			60	220	8				60	240	8								
500	127	620	28	210	230	20	M24	650	34	230	260	20	M30	635.0	46.0	250	280	20	1 1/8"-7 UNC
600	154	725	28	240	270	20	M27	770	36	260	290	20	M33	749.3	47.6	280	310	20	1 1/4"-7 UNC
700	165	840	30	260	280	20	M27	840	36	270	300	20	M30	863.5	52.5	310	340	24	1 1/4"-7 UNC
			80	8					85	300	8					110	8		
750	190	900	32	290	320	20	M30	900	38	300	340	80	M36	914.4	54.0	335	375	24	1 1/4"-7 UNC
			95	8					100	340	8					110	8		
800	190	950	32	290	320	20	M30	950	38	310	345	20	M36	978.0	57.0	340	380	24	1 1/2"-6 UNC
			110	8					80	345	8					95	8		
900	203	1050	34	310	350	24	M30	1070	40	330	375	24	M36	1086.0	60.0	370	415	28	1 1/2"-6 UNC
			100	8					100	375	8					110	8		
1000	216	1160	34	325	360	24	M33	1160	42	345	390	24	M39	1200.0	63.5	390	430	32	1 1/2"-6 UNC
			95	8					100	390	8					120	8		
1100	216	1270	38	330	370	28	M33	1270	48	360	400	28	M39	1314.5	101	465	410	36	1 1/2"-6 UNC
			100	8					110	400	8					150	8		
1200	254	1380	38	375	420	28	M36	1390	48	395	445	28	M45	1422.0	108.0	475	520	40	1 1/2"-6 UNC
			110	8					115	445	8					165	8		
1400	280	1590	42	410	450	32	M39	1590	52	440	490	32	M45	1651.0	124.0	580	630	44	1 3/4"-5 UNC
			120	8					120	490	8					160	8		
1600	318	1820	46	460	510	36	M45	1820	58	470	530	36	M52	-	-	-	-	-	-
			110	8					120	530	8								

* DN 25 - 600: ASME B16.5; DN 700 - 1200: ASME B16.47 Series A

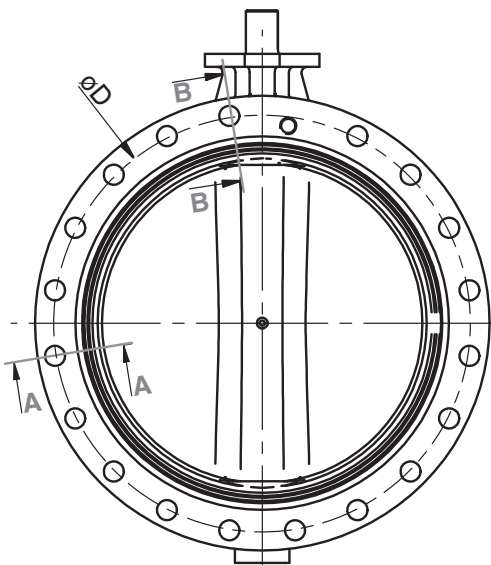

Flange holes are specially machined (finish as threaded holes)
DN 450, DN 700 - 1600

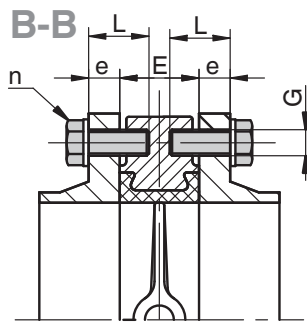
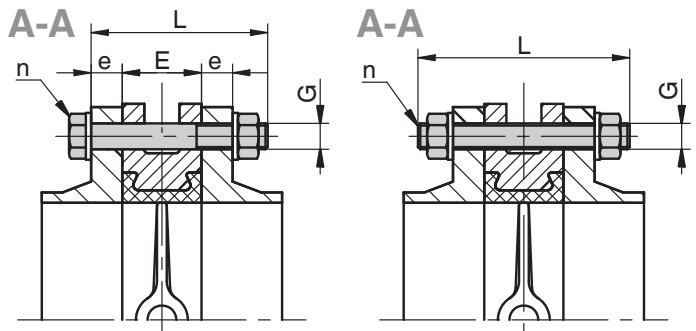

DN 450, DN 700 - 1600

n = number of holes

Availability / code - Body configuration / connection

Wafer																						
Flange	Nominal size																					
	25	32	40	50	65	80	100	125	150	200	250	300	350	400	450	500	600	700	800	900	1000	1200
PN 6	○	3	3	○	3	3	3	3	3	3	3	3	3	○	○	○	○	-	○	○	○	○
PN 10	3	3	3	3	3	3	3	3	3	3	3	3	3	3	2	2	2	2	2	2	2	2
PN 16	3	3	3	3	3	3	3	3	3	3	3	3	3	3	3	3	3	3	3	3	3	3
ASME B16.5 Class 150	○	D	D	D	D	D	D	D	D	D	D	D	D	D	D	D	D	○	-	-	○	○
ASME B16.47 Class 150	-	-	-	-	-	-	-	-	-	-	-	-	-	-	-	-	-	○	E	E	○	○
JIS 5k	○	K	K	-	K	K	K	K	K	K	K	K	○	○	○	○	○	○	○	○	○	○
JIS 10k	○	G	G	G	G	G	G	G	G	G	G	○	G	G	G	G	G	G	○	G	G	G
JIS 16k	○	J	J	○	○	J	J	J	○	J	○	○	○	J	J	J	J	-	J	J	J	J
BS 10 D	○	H	○	H	H	H	H	H	H	○	H	H	○	H	○	○	-	-	○	-	○	
BS 10 E	○	S	S	S	S	S	S	S	S	S	S	S	S	S	S	S	S	○	S	S	S	S
AS 2129 Tab E	○	U	U	○	U	U	U	U	U	U	U	U	U	○	U	○	○	○	○	○	○	-

Lug																					
Flange	25	32	40	50	65	80	100	125	150	200	250	300	350	400	450	500	600				
PN 6	1	1	1	1	1	1	○	1	1	1	1	1	1	1	1	1	○	○			
PN 10	3	3	3	3	3	3	3	3	3	3	2	2	2	2	2	2	2	2			
PN 16	3	3	3	3	3	3	3	3	3	3	3	3	3	3	3	3	3	3			
ASME B16.5 Class 150	D	D	D	D	D	D	D	D	D	D	D	D	D	D	D	D	D	D			
JIS 5k	K	K	K	-	K	K	K	K	K	K	K	K	○	K	K	K	K	K			
JIS 10k	G	G	G	G	G	G	G	G	G	G	○	G	G	G	G	G	○	○			
JIS 16k	J	J	J	○	○	J	J	J	○	J	○	○	○	J	J	○	J	○			
BS 10 D	H	H	H	H	H	H	○	H	H	H	○	H	H	○	○	○	○	○			
BS 10 E	S	S	S	S	S	S	S	S	S	S	S	S	S	○	S	○	○	○			
AS 2129 Tab E	U	U	U	U	U	U	U	U	U	U	U	U	U	○	U	○	○	○			

U section															
Flange	200	250	300	350	400	450	500	600	700	800	900	1000	1200	1400	
PN 6	○	1	○	○	○	○	○	○	-	○	○	○	○	1	
PN 10	2	2	2	2	2	2	2	2	2	2	2	2	2	2	
PN 16	3	3	3	3	3	3	3	3	3	3	3	3	3	3	
ASME B16.5 Class 150	D	D	D	D	D	D	D	D	○	-	○	-	-	-	
ASME B16.47 Class 150	-	-	-	-	-	-	-	-	○	E	○	E	E	E	
JIS 5k	○	K	○	○	○	○	○	K	K	○	K	○	○	-	
JIS 10k	G	G	○	G	G	G	G	G	G	G	G	G	G	-	
JIS 16k	J	-	J	J	J	J	J	J	-	J	J	J	J	-	
BS 10 D	H	H	H	H	○	H	○	○	-	-	H	-	-	-	
BS 10 E	S	S	S	S	○	S	○	○	-	-	S	-	-	-	
AS 2129 Tab E	U	U	U	U	○	U	○	○	○	○	U	U	U	-	

○ = on request

12 Operator size - Type D480 - Butterfly valve with bare shaft

Dimensions - Operator flange [mm]

DN	ISO	Q	Shaft connection*	G	E	T	S	Code
25-32	F07	70	D	□11	18			07 D11
40	F07	70	D	□11	18			07 D11
50	F07	70	D	□11	18			07 D11
65	F07	70	D	□11	18			07 D11
80	F07	70	D	□11	18			07 D11
100	F07	70	D	□11	18			07 D11
125	F07	70	D	□14	18			07 D14
150	F07	70	D	□14	18			07 D14
200	F07	70	D	□17	24			07 D17
250	F10	102	D	□22	32	70	3	10 D22
300	F10	102	D	□22	32	70	3	10 D22
350	F10	102	D	□22	32	70	3	10 D22
400	F12	125	D	□27	28	85	4	12 D27
450	F14	140	D	□36	37	100	4	14 D36
500	F14	140	D	□36	37	100	4	14 D36
600	F16	165	D	□46	47	130	5	16 D46
700	F25	254	V	∅65	106	200	5	25 V65
800	F25	254	V	∅80	106	200	5	25 V80
900	F25	254	V	∅80	110	200	5	25 V80
1000	F25	254	V	∅80	110	200	5	25 V80
1200	F30	298	V	∅100	120	230	5	30 V100

* D = Square, diagonal (standard); V = Round with single keyway

DN 32 - 600

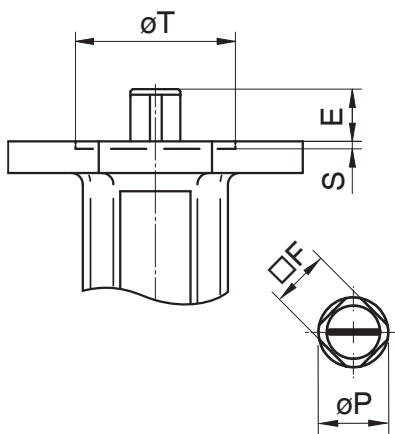

Shaft connection
Square, diagonal

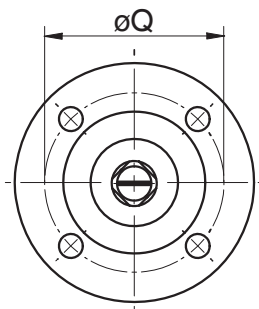

DN 700 - 1200

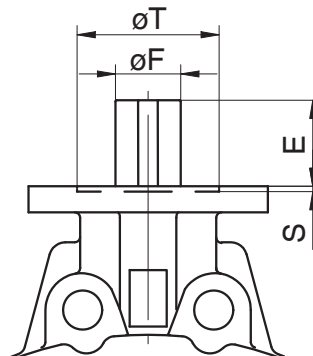

Shaft connection
Round with single keyway

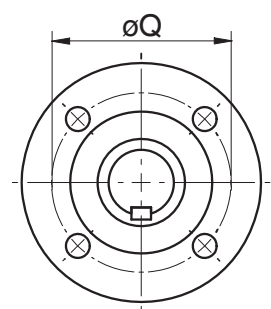

Order data

Order example	1	2	3	4	5	6	7	8	9	10	11	12
Code	D480	Order data butterfly valve (page 4,5)									F	07 D11

12 Order data / Dimensions - Type D487 Butterfly valve with hand lever [mm]

Latching hand lever with 10° notches

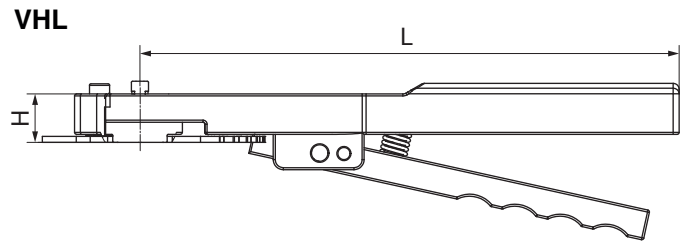
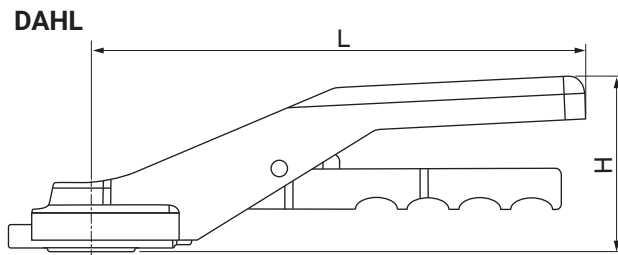

Hand lever						
DN	Order designation	Code	L	H	Weight [kg]	Top flange
25 - 200	VHL F0717.267	VHL17	267	24	1.20	F07
25-65	DAHL-F0711.200	DAHL11	200	79	0.50	F07
80 - 100	DAHL-F0711.270	DAHL11	270	82	0.60	F07
125 - 150	DAHL-F0714.270	DAHL14	270	88	0.68	F07
200	DAHL-F0717.315	DAHL17	315	88	0.70	F07

Continuously adjustable hand lever on request

The actuator designs apply to disc material code A, B, D, E, G, H, K in combination with shut off seal code E, N.

Order example	1	2	3	4	5	6	7	8	9	10	11	12
Code	D487	Order data butterfly valve (page 4,5)									0	MHL1731

12 Dimensions gear box/Code - valve with manual operator [mm]

GB232 / GBMDV3 - 4

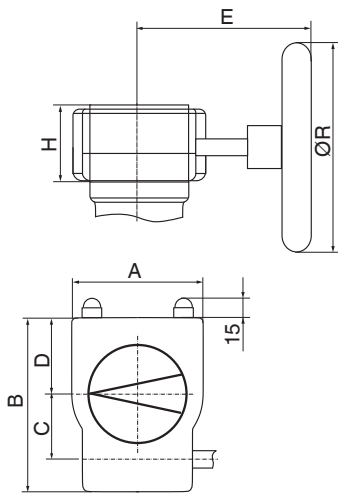

GBMDV5 - 8

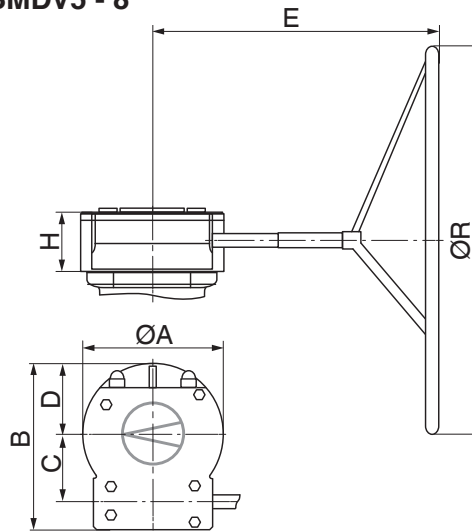

Gearbox / handwheel

DN	Order designation	Code	A	B	C	D	E	H	øR	n*	Weight [kg]
DN 32-100	GB23205F05-F07 D11 PS100	GB232	80	114	42.5	48.0	105	53	100	10.0	0.8
DN 125	GB23205F05-F07 D14 PS100	GB232	80	114	42.5	48.0	105	53	100	10.0	0.8
DN 150	GB23206F05-F07 D14 PS160	GB232	80	114	42.5	48.0	155	59	160	10.0	0.9
DN 200	GB23206F05-F07 D17 PS160	GB232	80	114	42.5	48.0	155	59	160	10.0	0.9
DN 250-300	GB23208F07-F10 D22 PS200	GB232	100	131	50.0	56.0	170	67	200	9.3	1.4
DN 350	GB23211F10-F12 D22 SG400	GB232	146	174	60.0	79.0	200	79	400	11.3	2.7
DN 400	GB23211F10-F12 D27 SG400	GB232	146	174	60.0	79.0	200	79	400	11.3	2.7
DN 450 - 500	GBMDV3F12-F16 D36 SG400	GBMDV3	180	235	96.5	91.5	321	100	400	12.0	18.4
DN 600	GBMDV4F16-F25 D46 SG500	GBMDV4	282	326	137.5	140.0	408	128	500	18.0	34.2
DN 700	GBMDV4F16-F25 V65 SG500	GBMDV4	282	326	137.5	140.0	408	128	500	18.0	34.2
DN 800	GBMDV5F16-F25 V80 SG600	GBMDV5	282	326	137.5	140.0	456	128	600	67.0	41.0
DN 900 - 1000	GBMDV7F25-F30 V80 SG700	GBMDV7	376	396	180	156.0	510	135	700	67.0	60.6
DN 1200	GBMDV8F25-F30 V100 SG700	GBMDV8	376	396	180	156.0	579	135	700	162.0	66.4

Material: Aluminium, polyurethane coated

n*: Handwheel turns OPEN/CLOSED

The actuator designs apply to disc material code A, B, D, E, G, H, K in combination with shut off seal code E, N.

Order data	1	2	3	4	5	6	7	8	9	10	11	12
Code	D487	Order data butterfly valve (page 4, 5)									0	GB232

Technical data - GEMÜ D481 with pneumatic actuator Type ADA/ASR



Control medium

Filtered, dry compressed air, non-corrosive medium

Temperature range

-30 to +100°C, other temperatures on request

Control pressure

6 - 8 bar

Angle of rotation

±4° adjustable (86° - 94°)

90°

12 Order data - GEMÜ D481 with pneumatic actuator Type ADA/ASR

Order example	1	2	3	4	5	5	6	7	8	9	10	11*	*see
Code	D481		Order data butterfly valve (page 4, 5)									BU08AC0	page 16

Stroke limiter on request

Technical data - GEMÜ D481 with pneumatic actuator Type DR/SC



Control medium

Filtered, dry compressed air, non-corrosive medium

Temperature range

-40 to +80°C, other temperatures on request

Control pressure

6 - 8 bar

Angle of rotation

20° adjustable (75° - 95°)

90°

12 Order data - GEMÜ D481 with pneumatic actuator Type DR/SC

Order example	1	2	3	4	5	6	7	8	9	10	11	12*	*see
Code	D481		Order data butterfly valve (page 4, 5)									DU06AC0	page 18

Stroke limiter on request

Actuator version* / Code - GEMÜ D481 with pneumatic actuator type ADA/ASR

Operating pressure 3 bar (see order data - operating pressure code 0)

DN	Pneumatic double acting	Code	Pneumatic single acting	Code
25	ADA0020U F05 Y S14/S11 A	BU02AB0	ASR0020U S08 F05 Y S14 A	AU02FB0
32	ADA0020U F05 Y S14/S11 A	BU02AB0	ASR0020U S08 F05 Y S14 A	AU02FB0
40	ADA0020U F05 Y S14/S11 A	BU02AB0	ASR0020U S08 F05 Y S14 A	AU02FB0
50	ADA0020U F05 Y S14/S11 A	BU02AB0	ASR0020U S08 F05 Y S14 A	AU02FB0
65	ADA0020U F05 Y S14/S11 A	BU02AB0	ASR0040U S14 F05 Y S14/S11 A	AU04KB0
80	ADA0020U F05 Y S14/S11 A	BU02AB0	ASR0040U S14 F05 Y S14/S11 A	AU04KB0
100	ADA0080U F05F07 Y S17/S14 A	BU08AC0	ASR0080U S14 F05F07 Y S17/S14 A	AU08KC0
125	ADA0080U F05F07 Y S17/S14 A	BU08AC0	ASR0130U S14 F05F07 Y S17/S14 A	AU13KC0
150	ADA0080U F05F07 Y S17/S14 A	BU08AC0	ASR0200U S14 F07F10 Y S17/S14 A	AU20KE0
200	ADA0130U F05F07 Y S 17/S14 A	BU13AC0	ASR0300U S14 F07F10 Y S22 A	AU30KD0
250	ADA0300U F07F10 Y S22 A	BU30AD0	ASR0500U S14 F10 Y S22 A	AU50KF0
300	ADA0300U F07F10 Y S22 A	BU30AD0	ASR0500U S14 F10 Y S22 A	AU50KF0
350	ADA0300U F07F10 Y S22 A	BU30AD0	ASR0850U S14 F10F12 Y S27 A	AU85KG0
400	ADA0850U F10F12 Y S27 A	BU85AG0	ASR1750U S14 F14 Y S36 A	A17UJK0
450	ADA1200U F10F14 Y S36 A	B12UAH0	ASR1750U S14 F14 Y S36 A	A17UJK0
500	ADA1200U F10F14 Y S36 A	B12UAH0	ASR2100U S14 F14 Y S36 A	A21UJK0
600	ADA1200U F10F14 Y S36 A	B12UAH0	ASR2500U S14 F16 Y S46 A	A25UKL0

Operating pressure 6 bar (see order data - operating pressure code 1)

25	ADA0020U F05 Y S14/S11 A	BU02AB0	ASR0020U S08 F05 Y S14 A	AU02FB0
32	ADA0020U F05 Y S14/S11 A	BU02AB0	ASR0020U S08 F05 Y S14 A	AU02FB0
40	ADA0020U F05 Y S14/S11 A	BU02AB0	ASR0020U S08 F05 Y S14 A	AU02FB0
50	ADA0020U F05 Y S14/S11 A	BU02AB0	ASR0020U S08 F05 Y S14 A	AU02FB0
65	ADA0020U F05 Y S14/S11 A	BU02AB0	ASR0040U S14 F05 Y S14/S11 A	AU04KB0
80	ADA0080U F05F07 Y S17/S14 A	BU08AC0	ASR0080U S14 F05F07 Y S17/S14 A	AU08KC0
100	ADA0080U F05F07 Y S17/S14 A	BU08AC0	ASR0080U S14 F05F07 Y S17/S14 A	AU08KC0
125	ADA0080U F05F07 Y S17/S14 A	BU08AC0	ASR0200U S14 F07F10 Y S17/S14 A	AU20KE0
150	ADA0080U F05F07 Y S17/S14 A	BU08AC0	ASR0300U S14 F07F10 Y S22 A	AU30KD0
200	ADA0200U F07F10 Y S17/S14 A	BU20AE0	ASR0500U S14 F07F10 Y S22 A	AU50KD0
250	ADA0300U F07F10 Y S22 A	BU30AD0	ASR0850U S14 F10F12 Y S27 A	AU85KG0
300	ADA0300U F07F10 Y S22 A	BU30AD0	ASR0850U S14 F10F12 Y S27 A	AU85KG0
350	ADA0500U F10 Y S22 A	BU50AF0	ASR1200U S14 F10F14 Y S36 A	A12UJH0
400	ADA0850U F10F12 Y S27 A	BU85AG0	ASR1750U S14 F14 Y S36 A	A17UJK0
450	ADA1750U F14 Y S36 A	B17UAK0	ASR2500U S14 F14 Y S36 A	A25UK10
500	ADA1750U F14 Y S36 A	B17UAK0	ASR4000U S14 F16F25 Y S55 A	A40UKM0
600	ADA2500U F16 Y S46 A	B25UAL0		

Operating pressure 10 bar (see order data - operating pressure code 2)

25	ADA0020U F05 Y S14/S11 A	BU02AB0	ASR0020U S08 F05 Y S14 A	AU02FB0
32	ADA0020U F05 Y S14/S11 A	BU02AB0	ASR0020U S08 F05 Y S14 A	AU02FB0
40	ADA0020U F05 Y S14/S11 A	BU02AB0	ASR0020U S08 F05 Y S14 A	AU02FB0
50	ADA0020U F05 Y S14/S11 A	BU02AB0	ASR0040U S14 F05 Y S14/S11 A	AU04KB0
65	ADA0080U F05F07 Y S17/S14 A	BU08AC0	ASR0080U S14 F05F07 Y S17/S14 A	AU08KC0
80	ADA0080U F05F07 Y S17/S14 A	BU08AC0	ASR0080U S14 F05F07 Y S17/S14 A	AU08KC0
100	ADA0080U F05F07 Y S17/S14 A	BU08AC0	ASR0130U S14 F05F07 Y S17/S14 A	AU13KC0
125	ADA0080U F05F07 Y S17/S14 A	BU08AC0	ASR0200U S14 F07F10 Y S17/S14 A	AU20KE0
150	ADA0130U F05F07 Y S17/S14 A	BU13AC0	ASR0300U S14 F07F10 Y S22 A	AU30KD0
200	ADA0200U F07F10 Y S17/S14 A	BU20AE0	ASR0500U S14 F07F10 Y S22 A	AU50KD0
250	ADA0300U F07F10 Y S22 A	BU30AD0	ASR0850U S14 F10F12 Y S27 A	AU85KG0
300	ADA0500U F10 Y S22 A	BU50AF0	ASR1200U S14 F10F14 Y S36 A	A12UJH0
350	ADA0850U F10F12 Y S27 A	BU85AG0	ASR1750U S14 F14 Y S36 A	A17UJK0
400	ADA1200U F10F12 Y S27 A	B12UAG0	ASR2100U S14 F14 Y S36 A	A21UK10
450	ADA2100U F14 Y S36 A	B21UA10	ASR4000U S14 F16F25 Y S55 A	A40UKM0
500	ADA2100U F14 Y S36 A	B21UA10		

Operating pressure 16 bar (see order data - operating pressure code 3)

25	ADA0020U F05 Y S14/S11 A	BU02AB0	ASR0040U S14 F05 Y S14/S11 A	AU04KB0
32	ADA0020U F05 Y S14/S11 A	BU02AB0	ASR0040U S14 F05 Y S14/S11 A	AU04KB0
40	ADA0020U F05 Y S14/S11 A	BU02AB0	ASR0040U S14 F05 Y S14/S11 A	AU04KB0
50	ADA0020U F05 Y S14/S11 A	BU02AB0	ASR0040U S14 F05 Y S14/S11 A	AU04KB0
65	ADA0080U F05F07 Y S17/S14 A	BU08AC0	ASR0080U S14 F05F07 Y S17/S14 A	AU08KC0
80	ADA0080U F05F07 Y S17/S14 A	BU08AC0	ASR0080U S14 F05F07 Y S17/S14 A	AU08KC0
100	ADA0080U F05F07 Y S17/S14 A	BU08AC0	ASR0200U S14 F07F10 Y S17/S14 A	AU20KE0
125	ADA0130U F05F07 Y S17/S14 A	BU13AC0	ASR0300U S14 F07F10 Y S22 A	AU30KD0
150	ADA0130U F05F07 Y S17/S14 A	BU13AC0	ASR0300U S14 F07F10 Y S22 A	AU30KD0
200	ADA0300U F07F10 Y S22 A	BU30AD0	ASR0850U S14 F10F12 Y S27 A	AU85KG0
250	ADA0500U F10 Y S22 A	BU50AF0	ASR1200U S14 F10F14 Y S36 A	A12UJH0
300	ADA0850U F10F12 Y S27 A	BU85AG0	ASR1750U S14 F14 Y S36 A	A17UJK0
350	ADA1200U F10F12 Y S27 A	B12UAG0	ASR2500U S14 F14 Y S36 A	A25UKK0
400	ADA1750U F14 Y S36 A	B17UAK0	ASR4000U S14 F16F25 Y S55 A	A25UK10
450	ADA2100U F14 Y S36 A	B21UA10		
500	ADA2500U F16 Y S46 A	B25UAL0		

* Technical data for liquids +20 to +80°C with control pressure 6 bar

The actuator designs apply to disc material code A, B, D, E, G, H, K in combination with shut off seal code E, N.

Actuator dimensions ADA/ASR [mm]

ADA/ASR 0020U-0850U

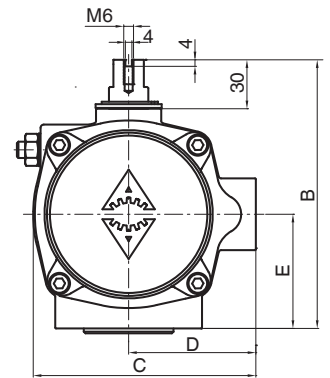
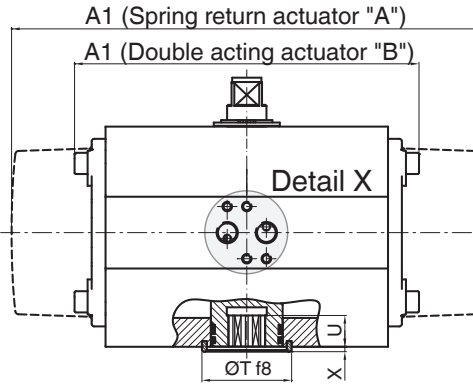
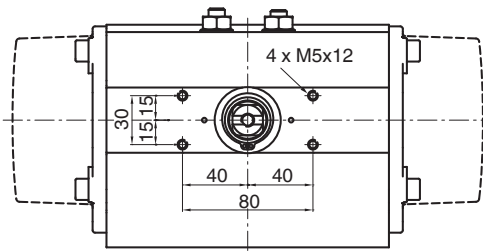

ADA/ASR 1200U-4000U

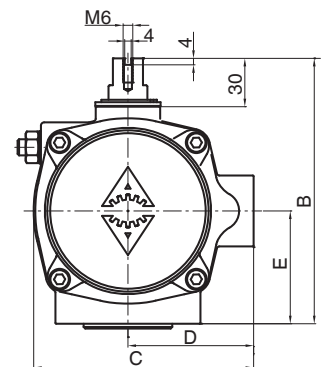
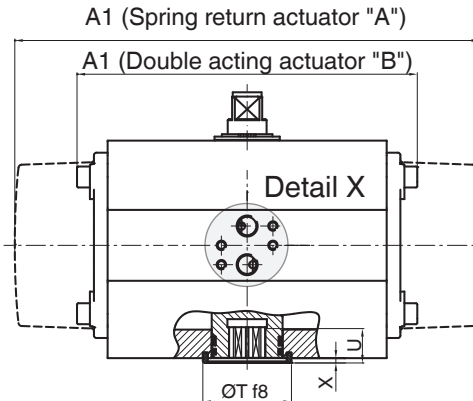
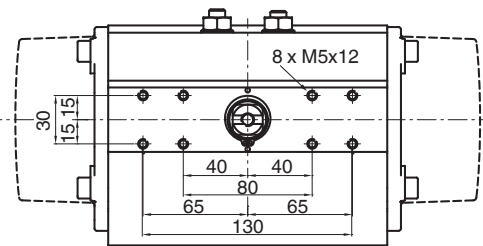

ADA/ASR
0020U-1750U

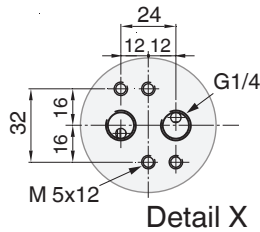

ADA/ASR
2100U-4000U

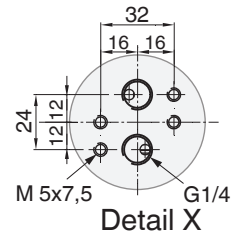

ADA/ASR	0020U		0040U		0080U	0130U	0200U	0300U	0500U	0850U	1200U	1750U	2100U		2500U	4000U		
ISO 5211	F03/ F05	F04	F05	F04	F05	F05	F05	F07	F07	F10	F10	F10	F14	F14	F16	F14	F16	F16
Octagonal	9	14	14	14	17	17	17	22	22	27	36	36	46	46	55			
Air connector		G1/4		G1/4	G1/4	G1/4	G1/4	G1/4	G1/4	G1/4	G1/4	G1/4	G1/4	G1/4	G1/4	G1/4	G1/4	G1/4
A		145		158	177	196	225	273	304	372	439	461	510	518	630			
A1		163		195	217	258	299	348.5	397	473	560	601	702	738	940			
B		96		115	137	147	165	182	199	221	249	280	313	383	434			
C		76		91	111	122	135.5	152.5	173	191.5	212.5	242.5	276.5	356	415			
D		48		56	66	71	78	86	96	106	116	131	148	177.5	213			
E		34		45	55	60	70	80	85	98	114	130	147	176.5	201			
ØT	25	35		35	55	55	55	70	70	85	100	100	130	130	200			
U	10	12		12	19	22	23	24	32	39	48	50	50	58	60			
Weight [kg]																		
ADA		1.4		2.1	3.0	3.8	5.6	8.5	11.2	16.9	25.8	32.5	49.0	69.6	129.4			
ASR		1.5		2.3	3.7	4.8	7.3	10.8	15.4	22.2	34.3	46.0	68.0	99.9	182.9			

Actuator version* / Code - GEMÜ D481 with pneumatic actuator type DR/SC

Operating pressure 3 bar (see order data - operating pressure code 0)

DN	Pneumatic double acting	Code	Pneumatic single acting	Code
25	DR0030U F05F07 N S14 A	DU03AP0	SC0030U 6 F05F07 N S14 A	SU03KP0
32	DR0030U F05F07 N S14 A	DU03AP0	SC0030U 6 F05F07 N S14 A	SU03KP0
40	DR0030U F05F07 N S14 A	DU03AP0	SC0030U 6 F05F07 N S14 A	SU03KP0
50	DR0030U F05F07 N S14 A	DU03AP0	SC0030U 6 F05F07 N S14 A	SU03KP0
65	DR0030U F05F07 N S14 A	DU03AP0	SC0060U 6 F05F07 N S14 A	SU06KP0
80	DR0030U F05F07 N S14 A	DU03AP0	SC0060U 6 F05F07 N S14 A	SU06KP0
100	DR0030U F05F07 N S14 A	DU03AP0	SC0060U 6 F05F07 N S14 A	SU06KP0
125	DR0060U F05F07 N S14 A	DU06AP0	SC0100U 6 F05F07 N S17 A	SU10KCO
150	DR0060U F05F07 N S14 A	DU06AP0	SC0150U 6 F05F07 N S17 A	SU15KCO
200	DR0100U F05F07 N S17 A	DU10AC0	SC0220U 6 F07F10 N S22 A	SU22KDO
250	DR0150U F07F10 N S22 A	DU15AD0	SC0300U 6 F07F10 N S22 A	SU30KDO
300	DR0220U F07F10 N S22 A	DU22AD0	SC0450U 6 F10F12 N S27 A	SU45KGO
350	DR0220U F07F10 N S22 A	DU22AD0	SC0600U 6 F10F12 N S27 A	SU60KGO
400	DR0450U F10F12 N S27 A	DU45AG0	SC2000U 6 F12 N D27 A	S20UKVO
450	DR0900U F14 N S36 A	DU90AK0	SC2000U 6 F12 N D27 A	S20UKKO
500	DR0900U F14 N S36 A	DU90AK0	SC2000U 6 F12 N D27 A	S20UKKO
600	DR1200U F14 N S36 A	D12UAK0	SC3000U 6 F16 N S46 A	S30UKLO

Operating pressure 6 bar (see order data - operating pressure code 1)

25	DR0030U F05F07 N S14 A	DU03AP0	SC0030U 6 F05F07 N S14 A	SU03KP0
32	DR0030U F05F07 N S14 A	DU03AP0	SC0030U 6 F05F07 N S14 A	SU03KP0
40	DR0030U F05F07 N S14 A	DU03AP0	SC0030U 6 F05F07 N S14 A	SU03KP0
50	DR0030U F05F07 N S14 A	DU03AP0	SC0030U 6 F05F07 N S14 A	SU03KP0
65	DR0030U F05F07 N S14 A	DU03AP0	SC0060U 6 F05F07 N S14 A	SU06KP0
80	DR0030U F05F07 N S14 A	DU03AP0	SC0060U 6 F05F07 N S14 A	SU06KP0
100	DR0030U F05F07 N S14 A	DU03AP0	SC0100U 6 F05F07 N S17 A	SU10KCO
125	DR0060U F05F07 N S14 A	DU06AP0	SC0150U 6 F05F07 N S17 A	SU15KCO
150	DR0100U F05F07 N S17 A	DU10AC0	SC0220U 6 F07F10 N S22 A	SU22KDO
200	DR0150U F05F07 N S17 A	DU15AC0	SC0300U 6 F07F10 N S22 A	SU30KDO
250	DR0220U F07F10 N S2 2A	DU22AD0	SC0600U 6 F10F12 N S27 A	SU60KGO
300	DR0300U F07F10 N S22 A	DU30AD0	SC0600U 6 F10F12 N S27 A	SU60KGO
350	DR0300U F07F10 N S22 A	DU30AD0	SC0900U 6 F10F12 N S27 A	SU90KGO
400	DR0600U F10F12 N S27 A	DU60AG0	SC2000U 6 F12 N D27 A	S20UKVO
450	DR1200U F14 N S36 A	D12UAK0	SC3000U 6 F14 N S36 A	S30UKKO
500	DR2000U F14 N S36 A	D20UAK0	SC4000U 6 F16 N S46 A	S40UKLO
600	DR3000U F16 N S46 A	D30UAL0	SC5000U 6 F16F25 N S46 A	S50UKSO

Operating pressure 10 bar (see order data - operating pressure code 2)

25		DU03AP0		SU03KP0
32	DR0030U F05F07 N S14 A	DU03AP0	SC0030U 6 F05F07 N S14 A	SU03KP0
40	DR0030U F05F07 N S14 A	DU03AP0	SC0030U 6 F05F07 N S14 A	SU03KP0
50	DR0030U F05F07 N S14 A	DU03AP0	SC0030U 6 F05F07 N S14 A	SU03KP0
65	DR0030U F05F07 N S14 A	DU03AP0	SC0060U 6 F05F07 N S14 A	SU06KP0
80	DR0030U F05F07 N S14 A	DU03AP0	SC0060U 6 F05F07 N S14 A	SU06KP0
100	DR0060U F05F07 N S14 A	DU06AP0	SC0100U 6 F05F07 N S17 A	SU10KCO
125	DR0100U F05F07 N S17 A	DU10AC0	SC0220U 6 F07F10 N S22 A	SU22KDO
150	DR0100U F05F07 N S17 A	DU10AC0	SC0220U 6 F07F10 N S22 A	SU22KDO
200	DR0150U F05F07 N S17 A	DU15AC0	SC0450U 6 F10F12 N S27 A	SU45KGO
250	DR0300U F07F10 N S22 A	DU30AD0	SC0600U 6 F10F12 N S27 A	SU60KGO
300	DR0450U F10F12 N S27 A	DU45AG0	SC1200U 6 F10F12 N S27 A	S12UKGO
350	DR0450U F10F12 N S27 A	DU45AG0	SC1200U 6 F10F12 N S27 A	S12UKGO
400	DR0900U F10F12 N S27 A	DU90AG0	SC3000U 6 F12 N D27 A	S30UKVO
450	DR2000U F14 N S36 A	D20UAK0	SC4000U 6 F16 N S46 A	S40UKLO
500	DR2000U F14 N S36 A	D20UAK0	SC5000U 6 F16F25 N S46 A	S50UKSO
600	DR4000U F16 N S46 A	D40UAL0		

Operating pressure 16 bar (see order data - operating pressure code 3)

25		DU03AP0		SU06KP0
32	DR0030U F05F07 N S14 A	DU03AP0	SC0060U 6 F05F07 N S14 A	SU06KP0
40	DR0030U F05F07 N S14 A	DU03AP0	SC0060U 6 F05F07 N S14 A	SU06KP0
50	DR0030U F05F07 N S14 A	DU03AP0	SC0060U 6 F05F07 N S14 A	SU06KP0
65	DR0030U F05F07 N S14 A	DU03AP0	SC0060U 6 F05F07 N S14 A	SU06KP0
80	DR0030U F05F07 N S14 A	DU03AP0	SC0100U 6 F05F07 N S17 A	SU10KCO
100	DR0060U F05F07 N S14 A	DU06AP0	SC0150U 6 F05F07 N S17 A	SU15KCO
125	DR0100U F05F07 N S17 A	DU10AC0	SC0220U 6 F07F10 N S22 A	SU22KDO
150	DR0100U F05F07 N S17 A	DU10AC0	SC0300U 6 F07F10 N S22 A	SU30KDO
200	DR0220U F07F10 N S22 A	DU22AD0	SC0600U 6 F10F12 N S27 A	SU60KGO
250	DR0450U F10F12 N S27 A	DU45AG0	SC0900U 6 F10F12 N S27 A	SU90KGO
300	DR0600U F10F12 N S27 A	DU60AG0	SC2000U 6 F12 N D27 A	S20UKVO
350	DR1200U F10F12 N S27 A	D12UAG0	SC3000U 6 F12 N D27 A	S30UKVO
400	DR2000U F14 N S36 A	D20UAK0	SC4000U 6 F16N S46 A	S40UKLO
450	DR2000U F14 N S36 A	D20UAK0		S50UKSO
500	DR3000U F16 N S46 A	D30UAL0		
600	DR4000U F16 N S46 A	D40UAL0		

*Technical data for liquids +20 to +80°C with control pressure 6 bar
The actuator designs apply to disc material code A, B, D, E, G, H, K in combination with shut off seal code E, N.

Actuator dimensions DR/SC [mm]

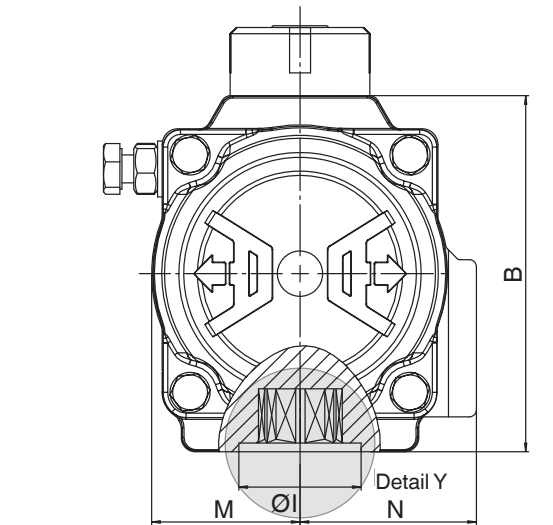
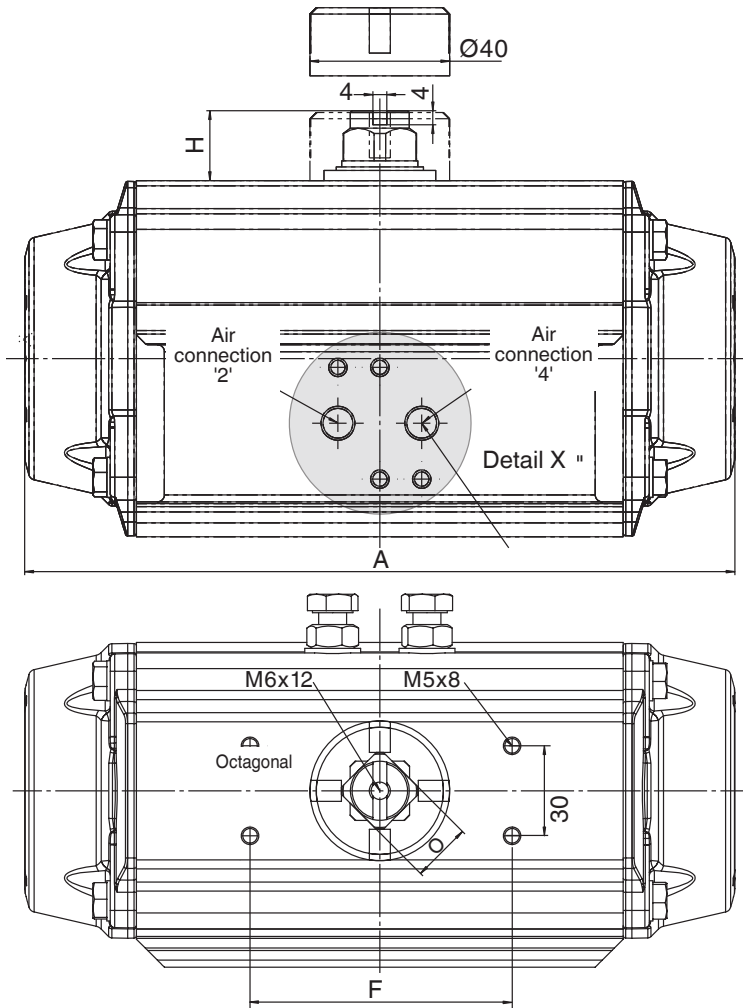

Type 0015U-1200U

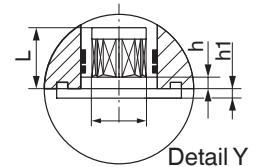
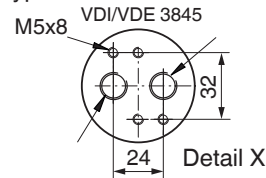

Type 2000U-4000U

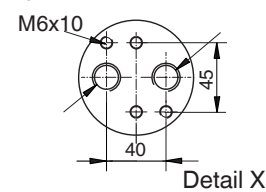

Type 5000U

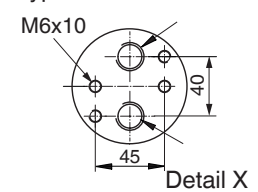

Type	0030U	0060U	0100U	0150U	0220U	0300U	0450U	0600U	0900U	1200U	2000U	3000U	4000U
ISO Flange	F04 F05/07	F05/07	F05/07	F07/10	F07/10	F07/10	F10/12	F10/12	F14	F14	F16	F16	F16
Octagonal	14	14	17	17	22	22	27	27	36	36	46	46	46
L	16	19	19	25	24	24	29	40	38	38	48	48	49
Air connector	G 1/8	G 1/8	G 1/8	G 1/4	G 1/4	G 1/4	G 1/4	G 1/4	G 1/4	G 1/4	G 3/8	G 1/2	G 1/2
A	153,5	203,5	241,0	259,0	304,0	333,0	394,5	422,5	474,0	528,0	605,0	710,0	812,0
B	85,0	102,0	115,0	127,0	145,0	157,0	177,0	196,0	220,5	245,0	298,5	330,0	383,0
F	80	80	80	80	80	80	80	80	130	130	130	130	130
H	20	20	20	20	30	30	30	30	50	50	50	50	50
Ø I	35	35	40	55	55	55	70	70	100	100	130	130	130
M	36,0	42,5	49,5	55,5	64,0	69,5	80,0	88,0	99,0	110,0	131,0	165,0	185,5
N	48,5	50,5	56,5	63,0	72,0	77,0	86,0	93,0	101,0	111,5	131,0	165,0	185,5
O	11	17	17	17	27	27	27	27	36	36	36	36	36
h	0,5	0,5	1,5	1,5	1,5	1,5	1,5	1,5	2	2	2,5	2,5	2,5
h1	1,5	2	1,5	2	2	2	3	3	3	3	2,5	2,5	4
L	11/16	19	19	19	19	25	32	40	38	38	38	40	57
Weight [kg]													
DR	1,6	2,7	3,7	5,2	8,0	9,8	14,0	18,0	24,0	34,0	53,0	74,0	123,0
SC	1,7	3,1	4,3	6,1	9,3	12,0	17,0	22,0	33,0	42,0	67,0	93,0	155,0

Technical data - Motorized GEMÜ actuators

Min. / max. ambient temperature

-10 to +60° C

Protection class to EN 60529

IP 65

Weight

Actuator version 1015	0.9 kg
Actuator version 2015	1.2 kg
Actuator version 3035	2.4 kg
Actuator version 2070	4.6 kg
Actuator version 4100, 4200	11.0 kg

Directives

EC Machinery directive 98/37/EC, annex II B

EC EMC directive 89/336/EEC

Special feature

Standard manual override

Power supply

Rated voltage	24 V DC / 24 V AC
Rated frequency at AC rated voltage	50/60 Hz
Voltage tolerance	+10% / -15%

Operating time

Actuator version 1015, 2015	approx. 11 sec
Actuator version 2070, 3035	approx. 15 sec
Actuator version 4100	approx. 20 sec
Actuator version 4200	approx. 16 sec

Actuator material

Actuator version	1015	2015, 3035
Housing base	PP (30 % gr)	PP (30 % gr)
Housing cover	PPO (10 % gr)	PP (30 % gr)
Indicator	PP-R natur	PP-R natur
Actuator version	2070	4100, 4200
Housing base	ABS	Aluminium
Housing cover	ABS	Aluminium
Indicator	PP-R natur	PMMA

gr = glass reinforced

Correlation actuator vers. / Voltage-frequency

Actuatorversion (code)	Supply voltage/mains frequency (code)	
	C1 24 V DC	C4 24 V AC
1015 (15 Nm)	X	-
2015 (15 Nm)	-	X
3035 (35 Nm)	X	X
2070 (70 Nm)	X	X
4100 (100 Nm)	X	X
4200 (200 Nm)	X	X

Power and current consumption

Actuator version code	24 V DC		24 V AC	
	A0/AE/AP	00/0E/0P	A0/AE/AP	00/0E/0P
	Power consumption [W]			
1015, 2015 (15 Nm)	30	-	40	-
3035 (35 Nm)	30	-	30	-
2070 (70 Nm)	96	63	-	63
4100 (100 Nm)	96	105	-	140
4200 (200 Nm)	96	90	-	110

Correlation actuator version / functional module

Actuator version code	Functional module (code)					
	A0	AE	AP	00	0E	0P
1015 (15 Nm)	X	X	-	-	-	-
2015 (15 Nm)	X	X	-	-	-	-
3035 (35 Nm)	X	X	-	-	-	-
2070 (70 Nm)	X	X	X	X	X	X
4100 (100 Nm)	X	X	X	X	X	X
4200 (200 Nm)	X	X	X	X	X	X

Note: For connection and wiring diagrams for motorized GEMÜ actuators see data sheet

Actuator version code 1015, 2015, 3035 - Data sheet GEMÜ 9428

Actuator version code 2070, 4100, 4200 - Data sheet GEMÜ 9468

Technical data - Motorized GEMÜ actuators

Travel	
Nominal travel	90°
Max. travel	93°
Setting range limit switch min.	0-20°
Setting range limit switch max.	70-93°

Rating	
100 %	

Correlation actuator version / nominal size						
DN	Actuator version (code)					
	1015 15 Nm	2015 15 Nm	3035 35 Nm	2070 70 Nm	4100 100 Nm	4200 200 Nm
40	X	X	-	-	-	-
50	-	-	X	-	-	-
65	-	-	X	-	-	-
80	-	-	-	X	-	-
100	-	-	-	X	-	-
125	-	-	-	-	X	-
150	-	-	-	-	-	X
200	-	-	-	-	-	X

The actuator designs apply to disc material code A, B, D, E, G, H, K in combination with shut off seal code E, N.

Order data - GEMÜ 488 with motorized GEMÜ actuators

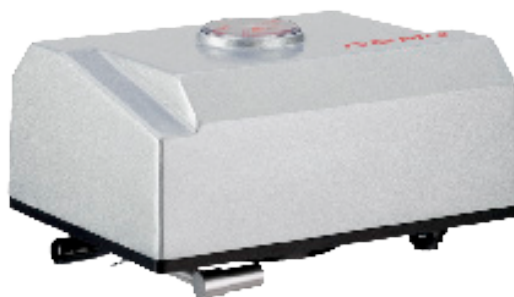

13 Voltage/frequency	Code
24 V DC	C1
24 V AC 50/60 Hz	C4

14 Control module	Code
ON/OFF actuator	A0
ON/OFF actuator, 2 additional potential-free limit switches, Class A (EN15714-2)	AE
ON/OFF actuator, potentiometer output, Class A (EN15714-2)	AP
ON/OFF actuator, relay, not reversible	00
ON/OFF actuator, 2 additional potential-free limit switches, relay, not reversible	0E
OPEN/CLOSE control, not reversible with potentiometer output	0P

15 Actuator version	Code
Actuator, motorized, operating time 11s, torque 15Nm, GEMUE, size 1, supply voltage B1, C1	1015
Actuator, motorized, operating time 11s, torque 15Nm, GEMUE, size 2, supply voltage B4, C4	2015
Actuator, motorized, operating time 15s, torque 35Nm, GEMUE, size 3, supply voltage C1	3035
Actuator, motorized, operating time 15s, torque 70Nm, GEMUE, size 2, supply voltage C1	2070
Actuator, motorized, operating time 20s, torque 100Nm, GEMUE, size 4, supply voltage C1	4100
Actuator, motorized, operating time 16s, torque 200Nm, GEMUE, size 4, supply voltage C1	4200

Technical data for liquids +20 to +80 °C

Order example	1	2	3	4	5	6	7	8	9	10	13	14	15
Code	D488	Order data butterfly valve (page 4, 5)									C1	A0	2070

Actuator dimensions [mm]

Actuator version 1015, 2015

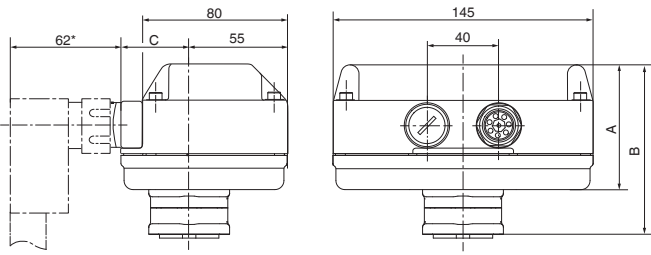

Voltages	A	B	C
24 V	69	94	49

Actuator version 3035

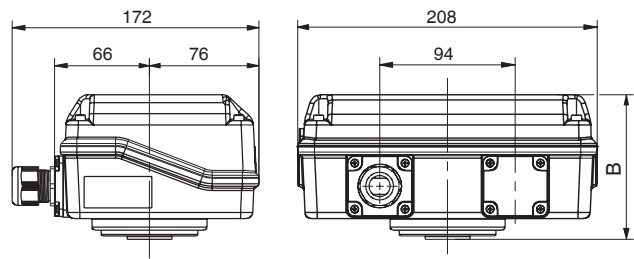

Voltages	B
24 V	100.5

Actuator version 2070

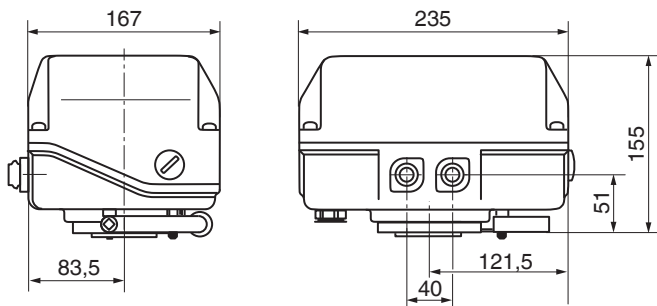

Actuator version 4100, 4200

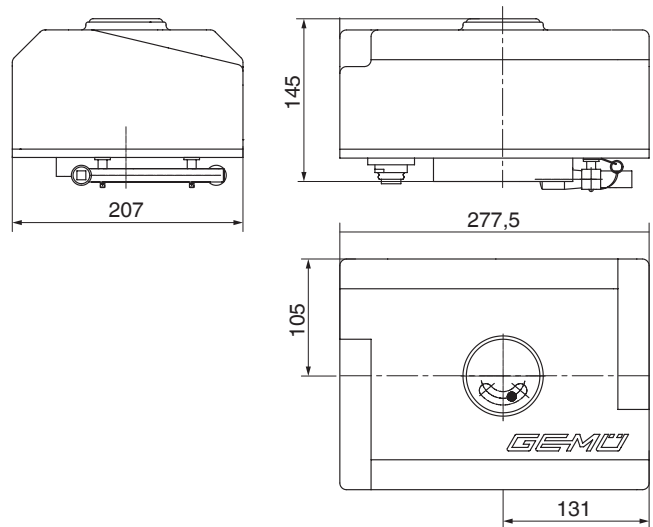

Technical data - Motorized J+J actuators

Min. / max. ambient temperature	
-20 to +70 °C	
Protection class to EN 60529	
IP 67 - J4C20, J4C35, J4C55 IP 65 - J2140, J2300	
Special feature	
Standard manual override	
Weight	
Actuator version J4C20	1.8 kg
Actuator version J4C35	1.9 kg
Actuator version J4C55	2.3 kg
Actuator version J2140 / J2300	5.2 kg
Power supply	
Rated voltage	
Version J4C14/30	24 V AC/DC (0/+5 %)
Version J4C20/35/55/85	24 - 240 V AC/DC (± 0%)
All versions	85 - 240 V AC/DC (0/+ 5%)
Rated frequency at AC rated voltage	50/60 Hz
Rating	75 %

Operating times (± 10%)

Actuator version	24- 240 V AC/DC Code U5	24 V, 85-240 V AC/DC Code C5, S5
J4C20	10 s	-
J4C35	10 s	-
J4C55	14 s	-
J4C85	30 s	-
J4C14	-	34 s
J4C30	-	58 s

Correlation actuator version / nominal size

DN	Actuator version - Standard (code)				
	J4C20 20 Nm	J4C35 35 Nm	J4C55 55 Nm	J2140 140 Nm	J2300 300 Nm
25-50	X	-	-	-	-
65-80	-	X	-	-	-
100	-	-	X	-	-
125-150	-	-	-	X	-
200-250	-	-	-	-	X

The actuator designs apply to disc material code A, B, D, E, G, H, K in combination with shut off seal code E, N.

Order data - GEMÜ D488 with motorized J+J actuators



13 Voltage/frequency	Code
24 V AC/DC (-0/+5 %) Version 140, 300	C5
24 - 240 V AC/DC (-0/+0 %) Version 20, 35, 55, 85	U5
85 - 240 V AC/DC (-0/+5 %) Version 140, 300	S5

Technical data for liquids +20 to +80 °C

14 Control module

Code	
ON/OFF actuator, 2 additional potential-free limit switches, Class A (EN15714-2)	AE
ON/OFF actuator, potentiometer output, Class A (EN15714-2)	AP
Control actuator, external set value 0/4-20 mA	E2
Control actuator, external set value 0-10 V DC	E1
Positioner DPS, external set value 0-10 V, BSR battery pack (NC)	E11
Positioner DPS, external set value 4-20mA, BSR battery pack (NC)	E21
ON/OFF actuator, 2 additional potential-free limit switches, BSR battery pack (NC)	AE1
ON/OFF actuator, 2 additional potential-free limit switches, BSR battery pack (NO)	AE2

15 Actuator version

Code	
Actuator, motorized, operating time 10s, torque 20Nm, J+J, type J4, heating, IP67	J4C20
Actuator, motorized, operating time 10s, torque 35Nm, J+J, type J4, heating, IP67	J4C35
Actuator, motorized, operating time 13s, torque 55Nm, J+J, type J4, heating, IP67	J4C55
Actuator, motorized, operating time 29s, torque 85Nm, J+J, type J4, heating, IP67	J4C85
Actuator, motorized, operating time 34s, torque 140Nm, J+J, type J4, heating, IP67	J4C14
Actuator, motorized, operating time 58s, torque 300Nm, J+J, type J4, heating, IP67	J4C30

Order example	1	2	3	4	5	6	7	8	9	10	13	14	15
Code	D488										U5	AE	J4C55

Actuator dimensions [mm]

Actuator version - J4C20 / J4C35

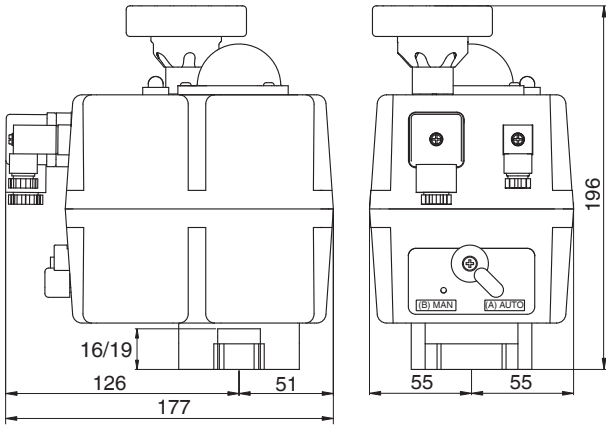

Actuator version - J4C55

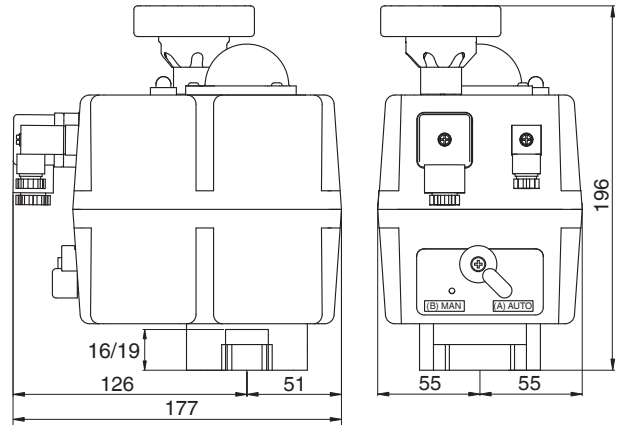

Actuator version - J2140 and J2300

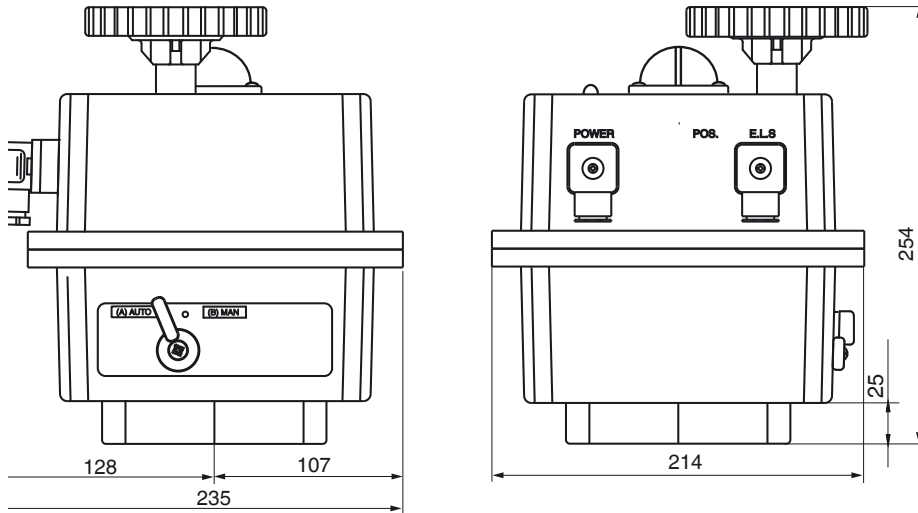

Certificate	Standard	Item number
2.1 Certificate of compliance with the order	EN 10204	88039442
2.2 Functionality	EN 10204/EN 12266-2 F20	88439527
2.2 Pressure test	EN 10204, DIN EN 12266 P10, P11, P12	88039443
3.1 Body material	EN 10204	88348926
3.1 Disc material	EN 10204	88348927
3.1 Pressure test	DIN EN 12266 P10, P11, P12	88348929
3.1 Layer thickness measurement		88413409

For further butterfly valves, accessories and other products, please see our Product Range catalogue and Price List.
Contact GEMÜ.

GEMÜ® VALVES, MEASUREMENT
AND CONTROL SYSTEMS

