



Model Number

NCN3-F31-N4-K

Features

- Direct mounting on standard actuators
- Compact and stable housing
- Fixed setting
- EC-Type Examination Certificate TÜV99 ATEX 1479X
- Usable up to SIL 2 acc. to IEC 61508

Accessories

BT65A

Activator for F31 series

BT65X

Activator for F31 series

BT115A

Activator for F31 series

BT115X

Activator for F31 series

BT65B

Activator for F31 series

BT115B

Activator for F31 series

Technical Data

General specifications

Switching function		2 x normally closed (NC)
Output type		NAMUR
Rated operating distance	s_n	3 mm
Installation		flush mountable
Assured operating distance	s_a	0 ... 2.4 mm
Actual operating distance	s_r	2.7 ... 3.3 mm typ.
Actuating element		Stainless steel 1.4305 / AISI 303 8.5 mm x 8.5 mm x 0.5 mm
Reduction factor r_{Al}		0.5
Reduction factor r_{Cu}		0.4
Reduction factor r_{304}		1
Reduction factor r_{St37}		1.3
Reduction factor r_{Brass}		0.6
Output type		2-wire

Nominal ratings

Nominal voltage	U_o	8 V
Switching frequency	f	0 ... 3 kHz
Hysteresis	H	typ. 5 %
Reverse polarity protection		reverse polarity protected
Short-circuit protection		yes
Suitable for 2:1 technology		yes , Reverse polarity protection diode not required
Current consumption		
Measuring plate not detected		≥ 3 mA
Measuring plate detected		≤ 1 mA
Time delay before availability	t_v	≤ 1.1 ms
Switching state indicator		LED, yellow

Functional safety related parameters

Safety Integrity Level (SIL)		SIL 2
MTTF _d		1470 a
Mission Time (T _M)		20 a
Diagnostic Coverage (DC)		0 %

Ambient conditions

Ambient temperature		-25 ... 100 °C (-13 ... 212 °F)
---------------------	--	---------------------------------

Note:

Under the same product name but with a different part no., this product has a predecessor with a restricted temperature range (up to +70 °C).

The temperature range specified here (up to +100°C) only applies to sensors with part no. 2239**.

Storage temperature		-40 ... 100 °C (-40 ... 212 °F)
---------------------	--	---------------------------------

Mechanical specifications

Connection (system side)		PVC cable , 5 m
Core cross-section (system side)		0.75 mm ²
Housing material		PBT
Sensing face		PBT
Degree of protection		IP66 / IP67
Cable		
Bending radius		> 10 x cable diameter

General information

Use in the hazardous area		see instruction manuals
---------------------------	--	-------------------------

Compliance with standards and directives

Standard conformity		
NAMUR		EN 60947-5-6:2000 IEC 60947-5-6:1999
Electromagnetic compatibility		NE 21:2007
Standards		EN 60947-5-2:2007 EN 60947-5-2/A1:2012 IEC 60947-5-2:2007 IEC 60947-5-2 AMD 1:2012

Approvals and certificates

EAC conformity		TR CU 012/2011
UL approval		cULus Listed, General Purpose
CSA approval		cCSAus Listed, General Purpose
CCC approval		CCC approval / marking not required for products rated ≤ 36 V

Dimensions

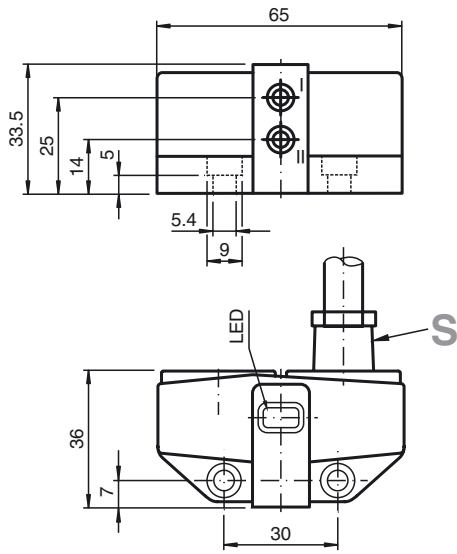

Electrical Connection

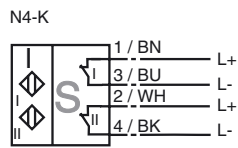

Data for application in connection with hazardous areas

Equipment protection level	Ga , Gb , Gc (ic) , Da , Mb
----------------------------	-----------------------------

Equipment protection level Ga

Type of protection	intrinsic safety
CE marking	CE 0102

Certificates

Appropriate type	NCN3-F31-N4...
ATEX certificate	TÜV 99 ATEX 1479 X
ATEX marking	Ⓔ II 1G Ex ia IIC T6...T1 Ga
Standards	EN 60079-0:2012+A11:2013 , EN 60079-11:2012
IECEX certificate	IECEX TUN 17.0021X
IECEX marking	Ex ia IIC T6...T1 Ga
Standards	IEC 60079-0:2011 , IEC 60079-11:2011

Effective internal inductivity	C_i	≤ 100 nF The value is applicable for one sensor circuit. A cable length of 10 m is considered.
--------------------------------	-------	---

Effective internal inductance	L_i	≤ 100 μ H The value is applicable for one sensor circuit. A cable length of 10 m is considered.
-------------------------------	-------	--

Maximum permissible ambient temperature T_{amb}	Also observe the maximum permissible ambient temperature stated in the general technical data. Keep to the lower of the two values.
---	--

for ATEX	<p>at $U_i = 15$ V , $I_i = 25$ mA , $P_i = 34$ mW , T6 : 55 °C (131 °F) T5 : 70 °C (158 °F) T4 : 95 °C (203 °F) T3 : 95 °C (203 °F) T2 : 95 °C (203 °F) T1 : 95 °C (203 °F)</p> <p>at $U_i = 15$ V , $I_i = 25$ mA , $P_i = 64$ mW , T6 : 55 °C (131 °F) T5 : 70 °C (158 °F) T4 : 95 °C (203 °F) T3 : 95 °C (203 °F) T2 : 95 °C (203 °F) T1 : 95 °C (203 °F)</p> <p>at $U_i = 15$ V , $I_i = 52$ mA , $P_i = 169$ mW , T6 : 50 °C (122 °F) T5 : 60 °C (140 °F) T4 : 90 °C (194 °F) T3 : 90 °C (194 °F) T2 : 90 °C (194 °F) T1 : 90 °C (194 °F)</p>
----------	--

for IECEX	<p>at $U_i = 15$ V , $I_i = 25$ mA , $P_i = 34$ mW , T6 : 75 °C (167 °F) T5 : 90 °C (194 °F) T4 : 100 °C (212 °F) T3 : 100 °C (212 °F) T2 : 100 °C (212 °F) T1 : 100 °C (212 °F)</p> <p>at $U_i = 15$ V , $I_i = 25$ mA , $P_i = 64$ mW , T6 : 75 °C (167 °F) T5 : 90 °C (194 °F) T4 : 100 °C (212 °F) T3 : 100 °C (212 °F) T2 : 100 °C (212 °F) T1 : 100 °C (212 °F)</p> <p>at $U_i = 15$ V , $I_i = 52$ mA , $P_i = 169$ mW , T6 : 65 °C (149 °F) T5 : 80 °C (176 °F) T4 : 90 °C (194 °F) T3 : 90 °C (194 °F) T2 : 90 °C (194 °F) T1 : 90 °C (194 °F)</p>
-----------	--

Release date: 2018-04-19 08:15 Date of issue: 2018-04-19 223954_eng.xml

Equipment protection level Gb

Type of protection	intrinsic safety	
CE marking	CE 0102	
Certificates		
Appropriate type	NCN3-F31-N4...	
ATEX certificate	TÜV 99 ATEX 1479 X	
ATEX marking	II 1G Ex ia IIC T6...T1 Ga	
Standards	EN 60079-0:2012+A11:2013 , EN 60079-11:2012	
IECEX certificate	IECEX TUN 17.0021X	
IECEX marking	Ex ia IIC T6...T1 Ga	
Standards	IEC 60079-0:2011 , IEC 60079-11:2011	
Effective internal inductivity	C_i	$\leq 100 \text{ nF}$ The value is applicable for one sensor circuit. A cable length of 10 m is considered.
Effective internal inductance	L_i	$\leq 100 \mu\text{H}$ The value is applicable for one sensor circuit. A cable length of 10 m is considered.
Maximum permissible ambient temperature T_{amb}	Also observe the maximum permissible ambient temperature stated in the general technical data. Keep to the lower of the two values. at $U_i = 15 \text{ V}$, $I_i = 25 \text{ mA}$, $P_i = 34 \text{ mW}$, T6 : 75 °C (167 °F) T5 : 90 °C (194 °F) T4 : 100 °C (212 °F) T3 : 100 °C (212 °F) T2 : 100 °C (212 °F) T1 : 100 °C (212 °F) at $U_i = 15 \text{ V}$, $I_i = 25 \text{ mA}$, $P_i = 64 \text{ mW}$, T6 : 75 °C (167 °F) T5 : 90 °C (194 °F) T4 : 100 °C (212 °F) T3 : 100 °C (212 °F) T2 : 100 °C (212 °F) T1 : 100 °C (212 °F) at $U_i = 15 \text{ V}$, $I_i = 52 \text{ mA}$, $P_i = 169 \text{ mW}$, T6 : 65 °C (149 °F) T5 : 80 °C (176 °F) T4 : 90 °C (194 °F) T3 : 90 °C (194 °F) T2 : 90 °C (194 °F) T1 : 90 °C (194 °F)	

Equipment protection level Gc (ic)

Type of protection	intrinsic safety	
CE marking	CE	
Certificates		
ATEX certificate	PF13CERT2895 X	
ATEX marking	II 3G Ex ic IIC T6...T1 Gc	
Standards	EN 60079-0:2012+A11:2013 , EN 60079-11:2012	
Effective internal inductivity	C_i	$\leq 100 \text{ nF}$ The value is applicable for one sensor circuit. A cable length of 10 m is considered.
Effective internal inductance	L_i	$\leq 100 \mu\text{H}$ The value is applicable for one sensor circuit. A cable length of 10 m is considered.
Maximum permissible ambient temperature T_{amb}	Also observe the maximum permissible ambient temperature stated in the general technical data. Keep to the lower of the two values. at $U_i = 20 \text{ V}$, $I_i = 25 \text{ mA}$, $P_i = 34 \text{ mW}$, T6 : 75 °C (167 °F) T5 : 90 °C (194 °F) T4 : 100 °C (212 °F) T3 : 100 °C (212 °F) T2 : 100 °C (212 °F) T1 : 100 °C (212 °F) at $U_i = 20 \text{ V}$, $I_i = 25 \text{ mA}$, $P_i = 64 \text{ mW}$, T6 : 75 °C (167 °F) T5 : 90 °C (194 °F) T4 : 100 °C (212 °F) T3 : 100 °C (212 °F) T2 : 100 °C (212 °F) T1 : 100 °C (212 °F) at $U_i = 20 \text{ V}$, $I_i = 52 \text{ mA}$, $P_i = 169 \text{ mW}$, T6 : 65 °C (149 °F) T5 : 80 °C (176 °F) T4 : 90 °C (194 °F) T3 : 90 °C (194 °F) T2 : 90 °C (194 °F) T1 : 90 °C (194 °F)	

Release date: 2018-04-19 08:15 Date of issue: 2018-04-19 223954_eng.xml

Equipment protection level Da

Type of protection	intrinsic safety	
CE marking	CE 0102	
Certificates		
Appropriate type	NCN3-F31-N4-K...	
ATEX certificate	TÜV 99 ATEX 1479 X	
ATEX marking	Ⓔ II 1D Ex ia IIIC T135°C Da	
Standards	EN 60079-0:2012+A11:2013 , EN 60079-11:2012	
IECEX certificate	IECEX TUN 17.0021X	
IECEX marking	Ex ia IIIC T135°C Da	
Standards	IEC 60079-0:2011 , IEC 60079-11:2011	
Effective internal inductivity	C_i	≤ 100 nF A cable length of 10 m is considered.
Effective internal inductance	L_i	≤ 100 μ H A cable length of 10 m is considered.
Maximum permissible ambient temperature T_{amb}	Also observe the maximum permissible ambient temperature stated in the general technical data. Keep to the lower of the two values. at $U_i = 15$ V , $I_i = 25$ mA , $P_i = 34$ mW : 100 °C (212 °F) at $U_i = 15$ V , $I_i = 25$ mA , $P_i = 64$ mW : 100 °C (212 °F) at $U_i = 15$ V , $I_i = 52$ mA , $P_i = 169$ mW : 90 °C (194 °F)	

Equipment protection level Mb

Type of protection	intrinsic safety	
CE marking	CE 0102	
Certificates		
Appropriate type	NCN3-F31-N4...	
IECEX certificate	IECEX TUN 17.0021X	
IECEX marking	Ex ia I Mb	
Standards	IEC 60079-0:2011 , IEC 60079-11:2011	
Effective internal inductivity	C_i	≤ 100 nF The value is applicable for one sensor circuit. A cable length of 10 m is considered.
Effective internal inductance	L_i	≤ 100 μ H The value is applicable for one sensor circuit. A cable length of 10 m is considered.
Maximum permissible ambient temperature T_{amb}	Also observe the maximum permissible ambient temperature stated in the general technical data. Keep to the lower of the two values. at $U_i = 15$ V , $I_i = 25$ mA , $P_i = 34$ mW : 100 °C (212 °F) at $U_i = 15$ V , $I_i = 25$ mA , $P_i = 64$ mW : 100 °C (212 °F) at $U_i = 15$ V , $I_i = 52$ mA , $P_i = 169$ mW : 90 °C (194 °F)	