



Type 100

Precision Air Pressure Regulator

Accurate, stable and dependable pressure regulation

The Type 100 is a high precision, multi-stage pressure regulator. This pressure controller provides the highest level of regulation accuracy and repeatability available. The Type 100 is ideal for applications that call for the utmost in control and maximum stability under variable operating conditions. A stainless steel measuring capsule is used as a sensing element to activate the high gain servo balanced control mechanism in which the main valve is controlled by a pilot valve. This allows for greater accuracy and eliminates many of the problems associated with conventional regulators using range springs and diaphragms.

Features

- **Accurate Pressure Regulation**
Controls output pressure to within 0.1% accuracy. Regulated pressure variation as small as 0.01 psig is self corrected
- **Stable Output**
Substantial changes in flow have virtually no effect on regulated pressure from dead end to 12 SCFM.
- **Dependable Startup**
Returns the regulated pressure to its original output setting even after long "down time"
- **High Relief Capacity**
An optional high flow relief valve provides quick response when regulated pressure is reset to a lower value or when there is a large amount of system back pressure to be relieved
- **Temperature Stability**
A stainless steel measuring capsule which activates the servo-control mechanism minimizes effects on regulated pressure by wide variations in operating temperature.
- **Locking Capability**
Locking nut prevents inadvertent pressure adjustment



Type 100 Precision Air Pressure Regulator

Applications

The Type 100 is well suited for processes that require precise regulation of air pressure in pipes and vessels. The Type 100 is often used, but not limited to the following applications:

Diagnostic Controls	Medical Instrumentation
Precision Fluid Control	Ventilators
Microfluidics	Gate Actuators
Air Gauging	Roll Loading
Gas Mixing	Valve Operators
Calibration Standards	Cylinder Loading
Air Hoists	Web Tensioning

Models

- Type 100 Standard** Standard version relief—offered in three pressure ranges (2-40 psi, 2-60 psi, 2-120 psi) and three port sizes (1/8", 1/4", 3/8").
- Type 100HR High Relief** High relief capacity allows for quick "blow-down" capability for rapid exhaust of output pressure. Ideal for pneumatic counter-balance applications.
- Type 100EHR Extra High Relief** Extra high relief allows quick "blow-down" for up to 15 scfm (450 NI/min) exhaust capacity.
- Type 100LR Low Range** Low range capability provides accurate pressure regulation at lower output range. Operates with an output pressure range of 0.5 psig to 25 psig. Maximum supply pressure is 50 psig.
- Type 100PL Plunger** Linear actuation of a plunger controls regulated pressure of a knob.
- Type 100BP Bottom Port** Bottom ported supply and output pressure, as well as four tapped mounting holes for manifold mounting. Suitable for applications with limited space.
- Type 100M Motorized** Motorized regulator. Regulation accuracy and sensitivity of the Type 100. Suitable for remote, "fail in place" applications. See website for more information.

Specifications

Flow Capacity	14 scfm (420 NI/min) at 100 psig (6.8 BAR) supply—20 psig (1.4 BAR) outlet
Exhaust Capacity	5 psig (0.4 BAR) above 20 psig (1.4 BAR) set point
Type 100	3 scfm (85 NI/min)
Type 100HR (High Relief)	11 scfm (311 NI/min)
Type-100EHR (Extra High Relief)	15 scfm (425 NI/min)
Sensitivity	1/8" (3.2 mm) water
Pilot Pressure Chamber Bleed Rate	less than 0.08 scfm (2.4 NI/min)
Total Air Consumption	6 scfh (3 NI/min)
Effect of Supply Pressure Variation of 25 psig (1.7 BAR) on outlet	less than .005 psig (0.003 BAR)
Supply Pressure, Maximum	150 psig (10.5 BAR); Type-100LR 50 psig (3.4 BAR)
Operating Temperature	-20° to 160°F (-29° to 71°C)
Materials:	
Body:	diecast zinc alloy
Capsule and adjusting screw:	stainless steel
Assemblies:	stainless steel, brass, plated steel, acetal
Diaphragms:	Buna-N elastomer and polyester fabric
Knob:	phenolic plastic
Weight	1.4 lb (635 g)
Port Sizes	1/8", 1/4", 3/8" NPT/BSP
Gauge Ports (2)	1/4" NPT/BSP
Output Pressure Ranges	0.5-25 psig (0.03 - 1.7 BAR) Type-100LR only 2-40 psig (0.14-2.7 BAR) 2-60 psig (0.14-4 BAR) 2-120 psig (0.14-8 BAR)
Mounting Options	pipe, panel or optional bracket

Flow Characteristics

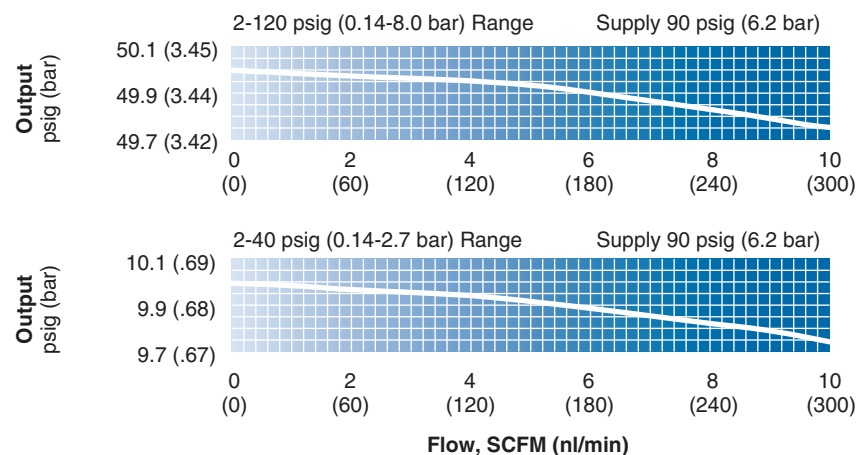

Accurate, stable and dependable pressure regulation

Plunger operation or manual knob adjustment

Compact size

Dependable start-up

Locking capability

Low range model with output pressure below 2.0 psig

High and Extra High relief models for fast exhaust of downstream pressure

Optional bottom porting for manifold mounting



Dimensions

- Type 100 Regulator
- Type 10HR High Relief Regulator
- Type-100EHR Extra High Relief
- Type 100LR Low Range Regulator

- Type 100BP Bottom Ported Regulator

Tamperproof Cover

Type 100 BP shown with optional tamperproof cover (available with Type 100, Type 100HR and Type 100LR).

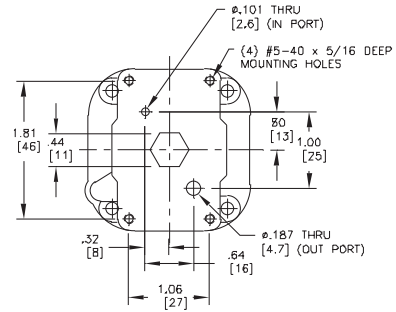
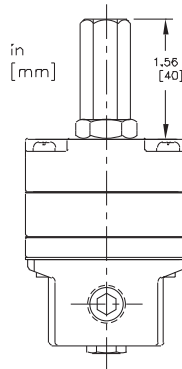
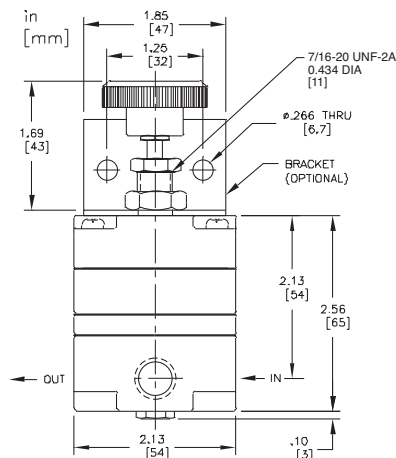

- Type 100PL Plunger Operated Regulator

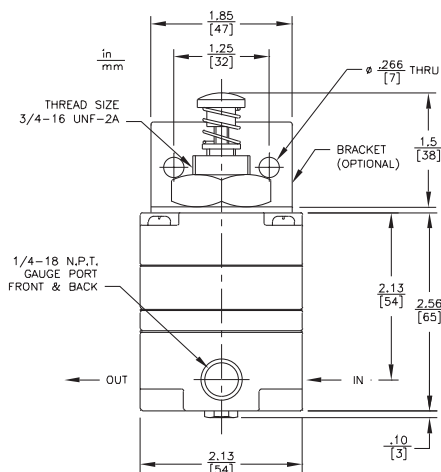

Plunger Travel

Pressure Range psig (BAR)	Plunger Travel* in (mm)
2-40 (0.14-2.7)	.120 (3.0)
2-60 (0.14-4.1)	.90 (2.3)
2-120 (0.14-8.2)	.100 (2.5)

* +/- 10% manufacturer tolerance

Return Spring

0.4 in. (10 mm) nominal return height; 7 oz. (200 g) approximate preload force. 7.5 lb./in. (135 g/mm) approximate spring rate, between 0.4 in. (10 mm) and .24 in. (6.5 mm) compressed height

Type 100 Precision Air Pressure Regulator

Principles of Operation

The measuring capsule in the Type 100 is the sensing element that controls a high precision, balanced servo-mechanism.

Stainless steel alloy construction gives the measuring capsule the ability to maintain forces over long periods of time without hysteresis. This eliminates problems associated with regulators that are controlled

by a range spring. The downstream regulated pressure fills the control chamber and surrounds the measuring capsule. Expansion, contraction, or other slight movement of the capsule causes the pilot valve to open or close. This creates a substantial pressure change within the pilot pressure chamber. The change in pilot pressure is directly proportional to the downward force on the pilot diaphragm which causes the appropriate movement of the supply valve or relief valve and corrects any variation from set pressure. The high gain nature of this servomechanism allows the Type 100 to react to changes in set pressure as little as 0.01 psig.

Regulated pressure applies an upward force on the underside of the control diaphragm. When set pressure drifts above the set point the control diaphragm assembly moves upward and allows excess pressure to be vented out of the relief valve to atmosphere. The design of the relief valve permits substantial reverse flow capacity which quickly exhausts system back pressure thus eliminating the need for a separate relief valve.

Drawing downloads available at www.controlair.com

Warranty ControlAir, Inc. products are warranted to be free from defects in materials and workmanship for a period of eighteen months from the date of sale, provided said products are used according to ControlAir, Inc. recommended usages. ControlAir, Inc.'s liability is limited to the repair, purchase price refund, or replacement in kind, at ControlAir, Inc.'s sole option, of any products proved defective. ControlAir, Inc. reserves the right to discontinue manufacture of any products or change products materials, designs or specifications without notice. Note: ControlAir does not assume responsibility for the selection, use, or maintenance of any product. Responsibility for the proper selection, use, and maintenance of any ControlAir product remains solely with the purchaser and end user. Drawing downloads available at www.controlair.com

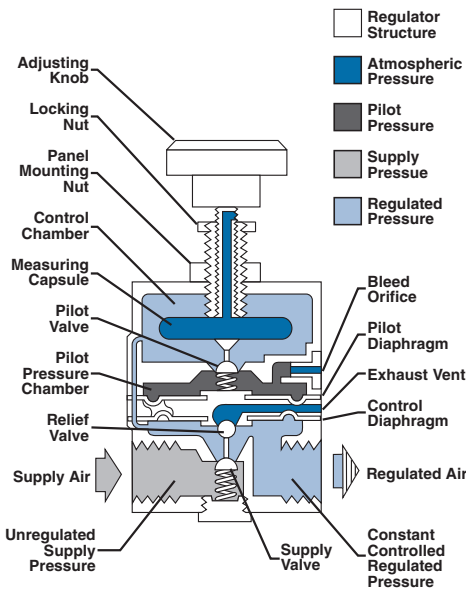

Ordering

Type	Port Size (NPT/BSP)	Output Range psig (BAR)	Part Number	
			NPT	BSP
100	1/8"	2-40 (0.14-2.7)	100-AA	100-AAU
100	1/8"	2-60 (0.14-4.1)	100-AB	100-ABU
100	1/8"	2-120 (0.14-8.2)	100-AC	100-ACU
100	1/4"	2-40 (0.14-2.7)	100-BA	100-BAU
100	1/4"	2-60 (0.14-4.1)	100-BB	100-BBU
100	1/4"	2-120 (0.14-8.2)	100-BC	100-BCU
100	3/8"	2-40 (0.14-2.7)	100-CA	100-CAU
100	3/8"	2-60 (0.14-4.1)	100-CB	100-CBU
100	3/8"	2-120 (0.14-8.2)	100-CC	100-CCU
100HR	1/4"	2-120 (0.14-8.2)	110-BC	110-BCU
100HR	3/8"	2-120 (0.14-8.2)	110-CC	110-CCU
100EHR	1/4"	2-120 (0.14-8.2)	111-BC	111-BCU
100EHR	3/8"	2-120 (0.14-8.2)	111-CC	111-CCU
100LR	1/4"	.5-25 (0.03-1.7)	120-BA	120-BAU
100BP	-	2-40 (0.14-2.7)	140-BA	140-BAU
100BP	-	2-60 (0.14-4.1)	140-BB	140-BBU
100BP	-	2-120 (0.14-8.2)	140-BC	140-BCU
100PL	1/8"	2-40 (0.14-2.7)	150-AA	150-AAU
100PL	1/8"	2-60 (0.14-4.1)	150-AB	150-ABU
100PL	1/8"	2-120 (0.14-8.2)	150-AC	150-ACU
100PL	1/4"	2-40 (0.14-2.7)	150-BA	150-BAU
100PL	1/4"	2-60 (0.14-4.1)	150-BB	150-BBU
100PL	1/4"	2-120 (0.14-8.2)	150-BC	150-BCU
100PL	3/8"	2-40 (0.14-2.7)	150-CA	150-CAU
100PL	3/8"	2-60 (0.14-4.1)	150-CB	150-CBU
100PL	3/8"	2-120 (0.14-8.2)	150-CC	150-CCU

Options

Tamperproof Cover - Add "T" at end of part number (See drawing for dimensions)

Preset Pressure - Output pressure can be preset at factory. (Consult factory for ordering information)

Tapped Exhaust - To order with a 10-32 tapped exhaust vent and barbed bleed screw, add an "E" to end of part number

Oxygen Compatible - Consult factory for ordering information

BSP Porting - To order with BSP porting, add "U" to end of part number

Accessories

Mounting Bracket: P/N 446-707-045

Gauges: 1/4" NPT back-mount, 2" face, dual scale

0-15 psi P/N 446-725-003

0-30psi P/N 446-725-004

0-60 psi P/N 446-725-001

0-160 psi P/N 446-725-002



8 Columbia Drive / Amherst, NH 03031 USA / www.controlair.com / sales@controlair.com / 603-886-9400 / FAX 603-889-1844

An ISO 9001:2015 Registered Company