

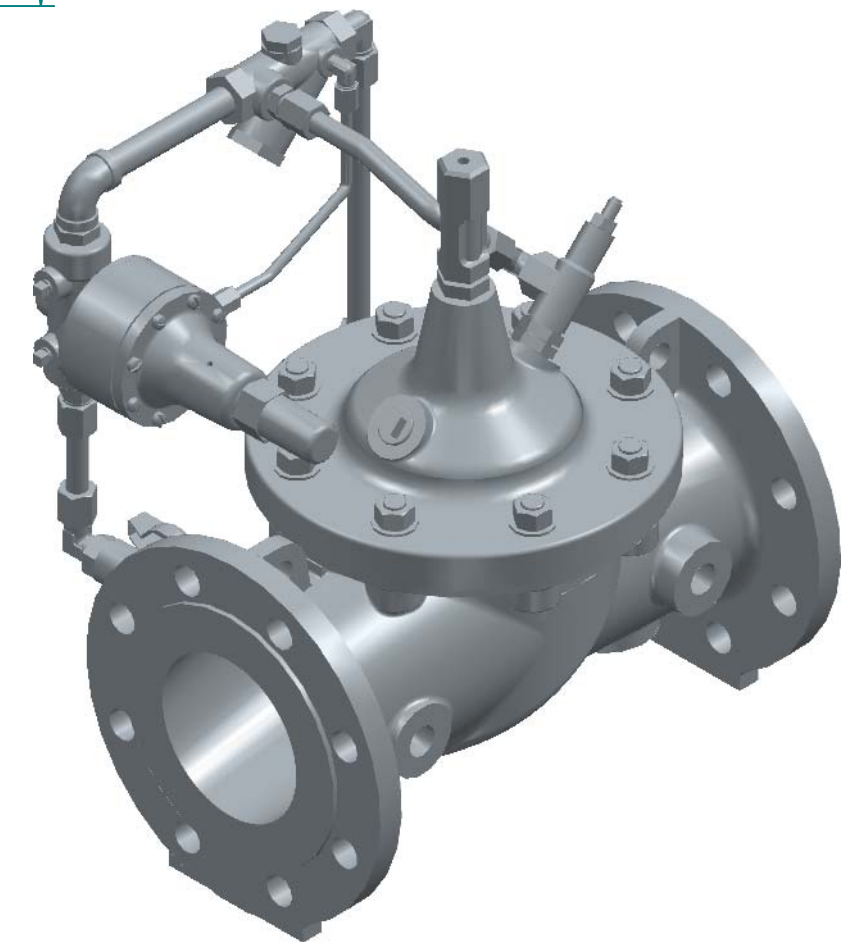

Cla-Val 50-01 Standard Equipment

No	Description	Qty	Type
1	Main Valve Hytrol NGE	1	100-01
2	Isolation Ball Valve	2	RB-117
3	Strainer With Incorporated Orifice	1	X44-A
4	Pressure Relief Control	1	CRL
5	Needle Valve	1	6120

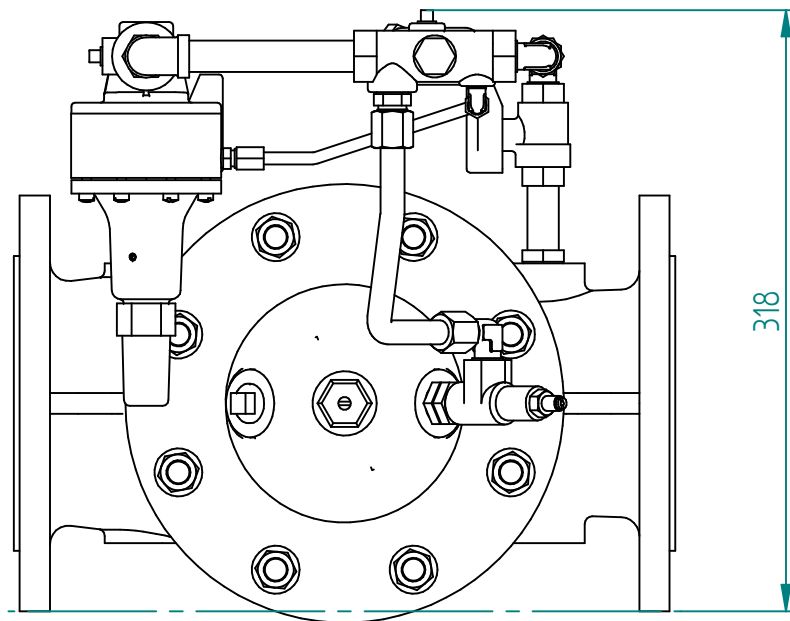
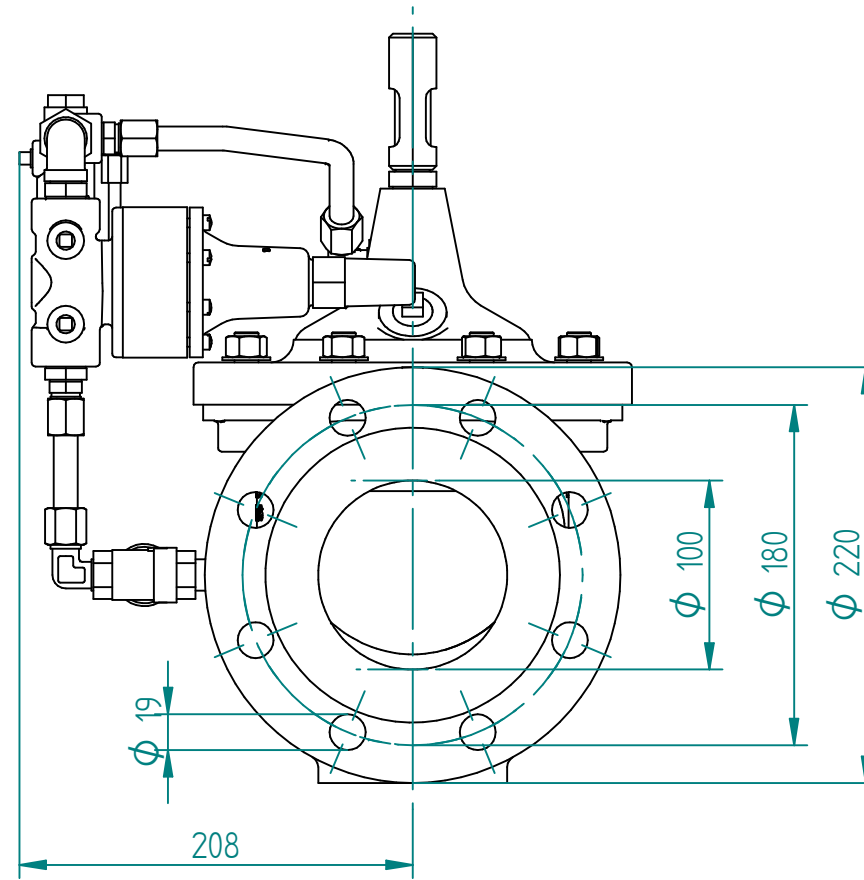
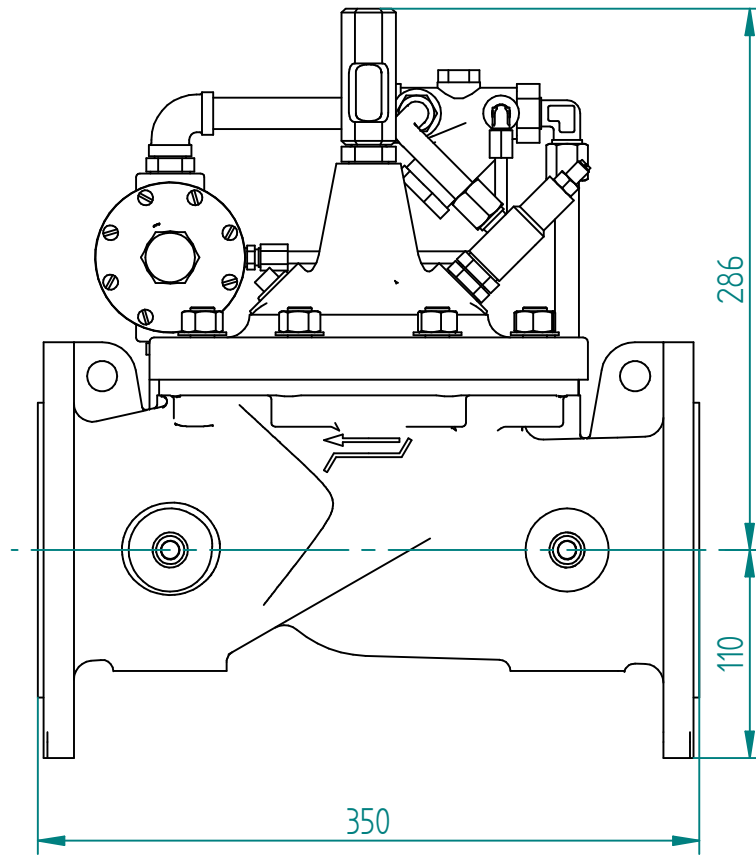

\*The actual weight and dimensions may vary when considering all peripheral equipment.

	NAME	RAGA	DATE	14.11.2023	SIZE	A3	DWG NO	CLA50-01-100	UNLESS OTHERWISE SPECIFIED DIMENSIONS ARE IN MILLIMETERS AND TOLERANCES ARE +/-0,5				
	DRAWN	RAGA	DATE	14.11.2023	FILE NAME:	CLA50-01-100.dft				00	Created		
	CHECKED	TOCO	DATE	dd.mm.yyyy	SCALE:	1:4	REV:	00		REV	DESCRIPTION	DATE	APPROVED
	ENG APPR	TOCO	DATE	dd.mm.yyyy	WEIGHT:	40 kg*	SHEET:	1 OF 1		REVISION HISTORY			
TITLE NG1E-50-01 KCOS DN100 PN10/16 CRL:1.4-14 BAR		MGR APPR	TOCO	DATE	dd.mm.yyyy								