

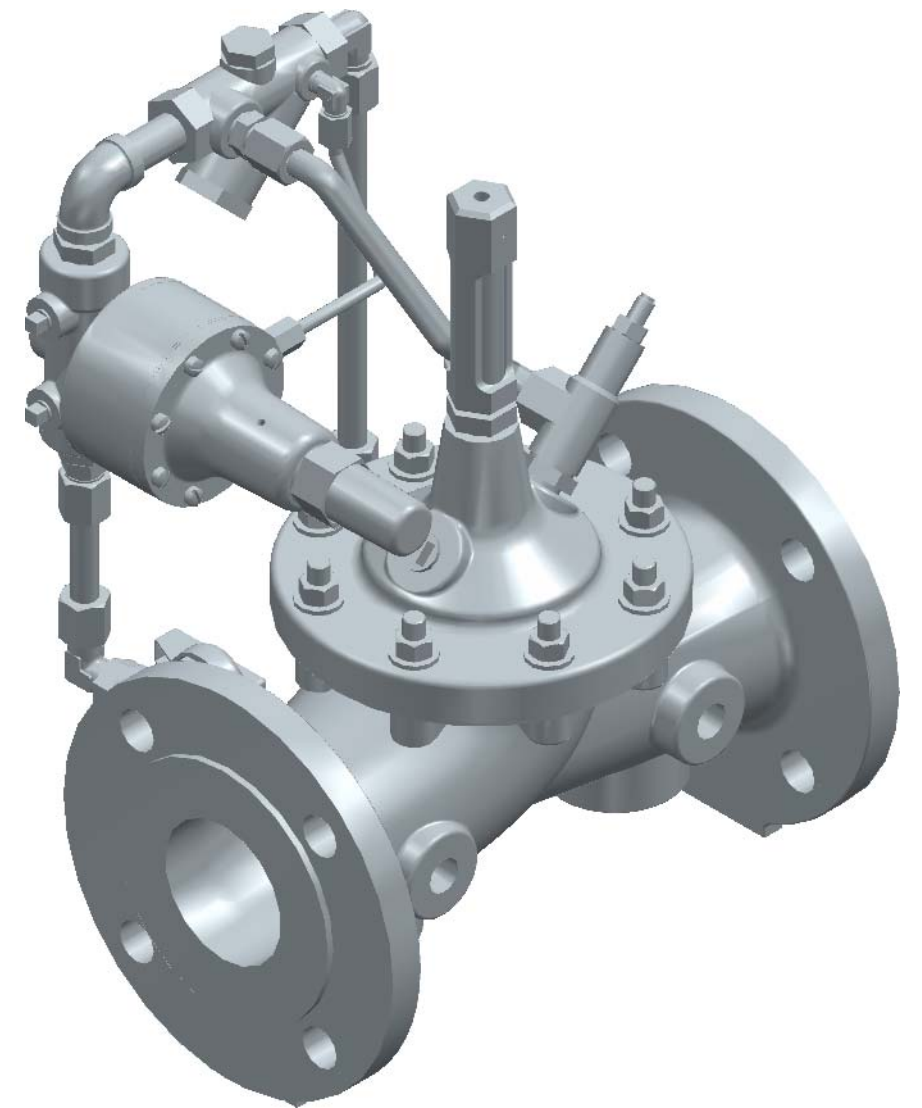

Cla-Val 50-01 Standard Equipment			
No	Description	Qty	Type
1	Main Valve Hytrol NGE	1	100-01
2	Isolation Ball Valve	2	RB-117
3	Strainer With Incorporated Orifice	1	X44-A
4	Pressure Relief Control	1	CRL
5	Needle Valve	1	6120

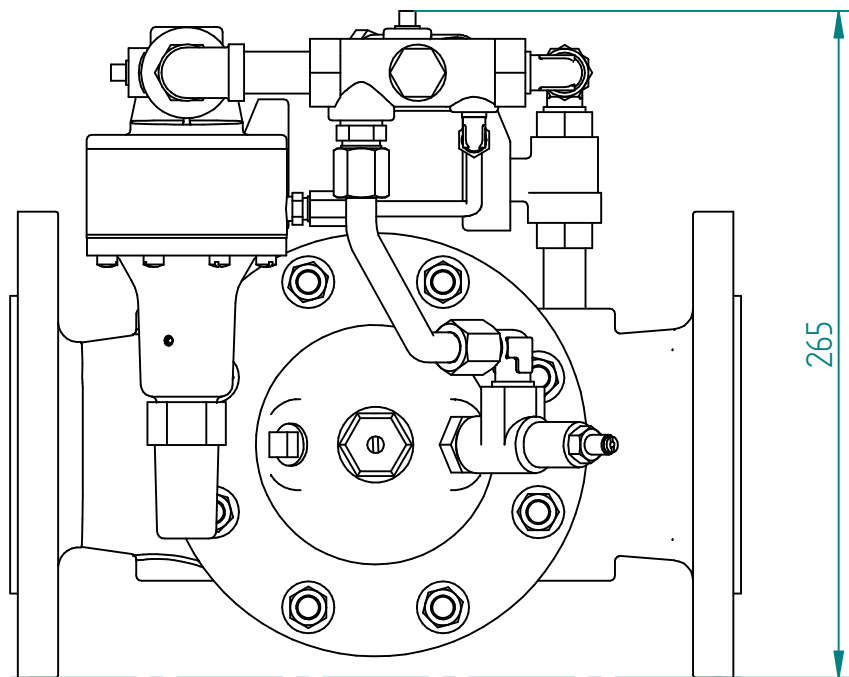

*The actual weight and dimensions may vary when considering all peripheral equipment.

	NAME	DATE	SIZE	DWG NO	UNLESS OTHERWISE SPECIFIED DIMENSIONS ARE IN MILLIMETERS AND TOLERANCES ARE +/-0,5				
	DRAWN	RAGA	14.11.2023	A3		CLA50-01-065			
	CHECKED	TOCO	dd.mm.yyyy	FILE NAME: CLA50-01-065.dft					
	ENG APPR	TOCO	dd.mm.yyyy	SCALE: 1:3		REV: 00			
	MGR APPR	TOCO	dd.mm.yyyy	WEIGHT: 20 kg*	SHEET: 1 OF 1				
TITLE NG1E-50-01 KCOS DN65 PN10/16 CRL:1.4-14 BAR									
						00	Created		
						REV	DESCRIPTION	DATE	APPROVED
						REVISION HISTORY			