

No.	Part Name	Material	Qty.
1	Body	Ductile Iron	1
2	Disc	Aluminum Bronze	1
3	Stem	Stainless Steel	1
4	Seat	BUNA-N	1

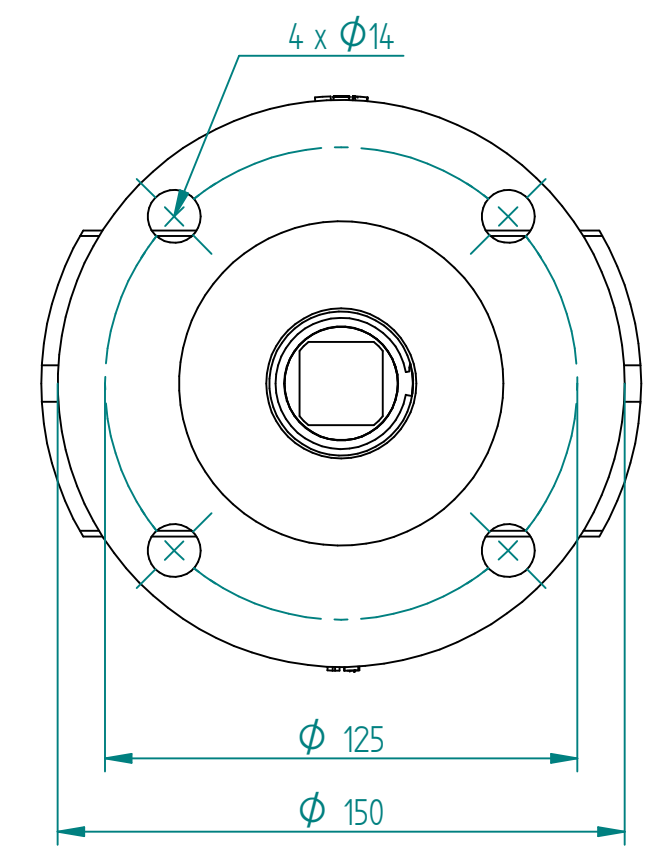
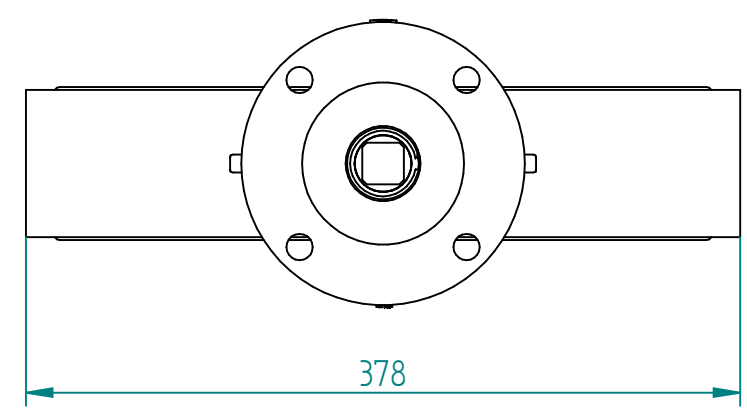

		NAME	DATE	SIZE	DWG NO
TITLE	DRAWN	MOTO	11.08.2014	A3	BRA15300
	CHECKED	TOCO	11.08.2014	FILE NAME: BRA15300.dft	
	ENG APPR	TOCO	dd.mm.yyyy	SCALE: 1:4	REV: .....
	MGR APPR	TOCO	dd.mm.yyyy	WEIGHT: 30,0 kg	SHEET: 1 OF 1

UNLESS OTHERWISE SPECIFIED DIMENSIONS ARE IN MILLIMETERS AND TOLERANCES ARE +/-0,5

REV	DESCRIPTION	DATE	APPROVED
REVISION HISTORY			

1:2 Top Plate