

No.	Part Name	Material	Qty.
1	Body	Stainless Steel, ASTM A351 GR CF8M	1
2	Disc	Stainless Steel, ASTM A351 GR CF8M	1
3	Stem	17-4 PH SS	1
4	Seat	RTFE	1

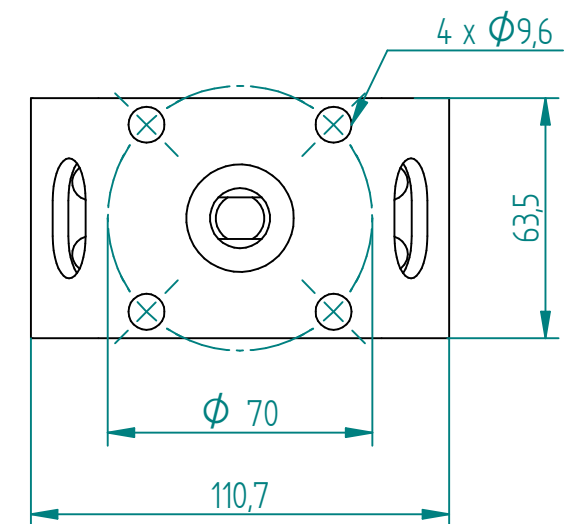
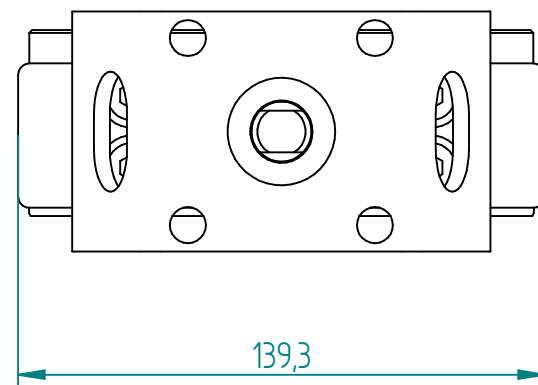
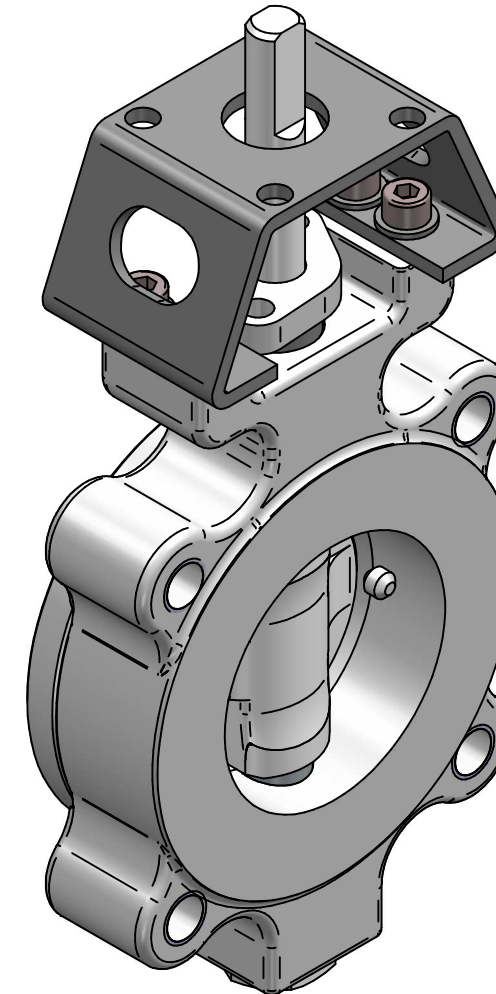
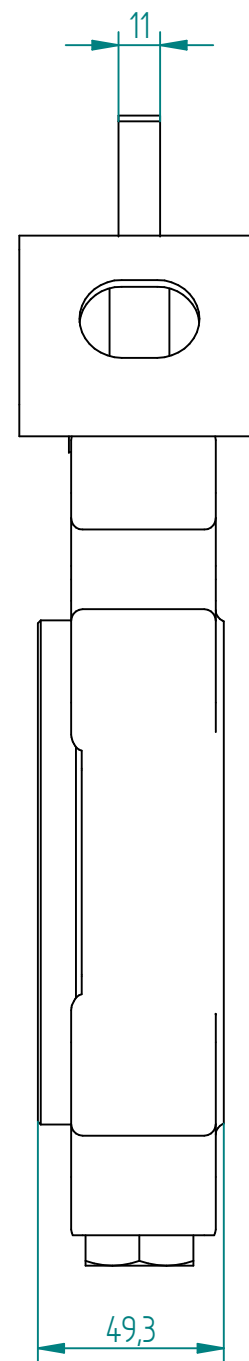
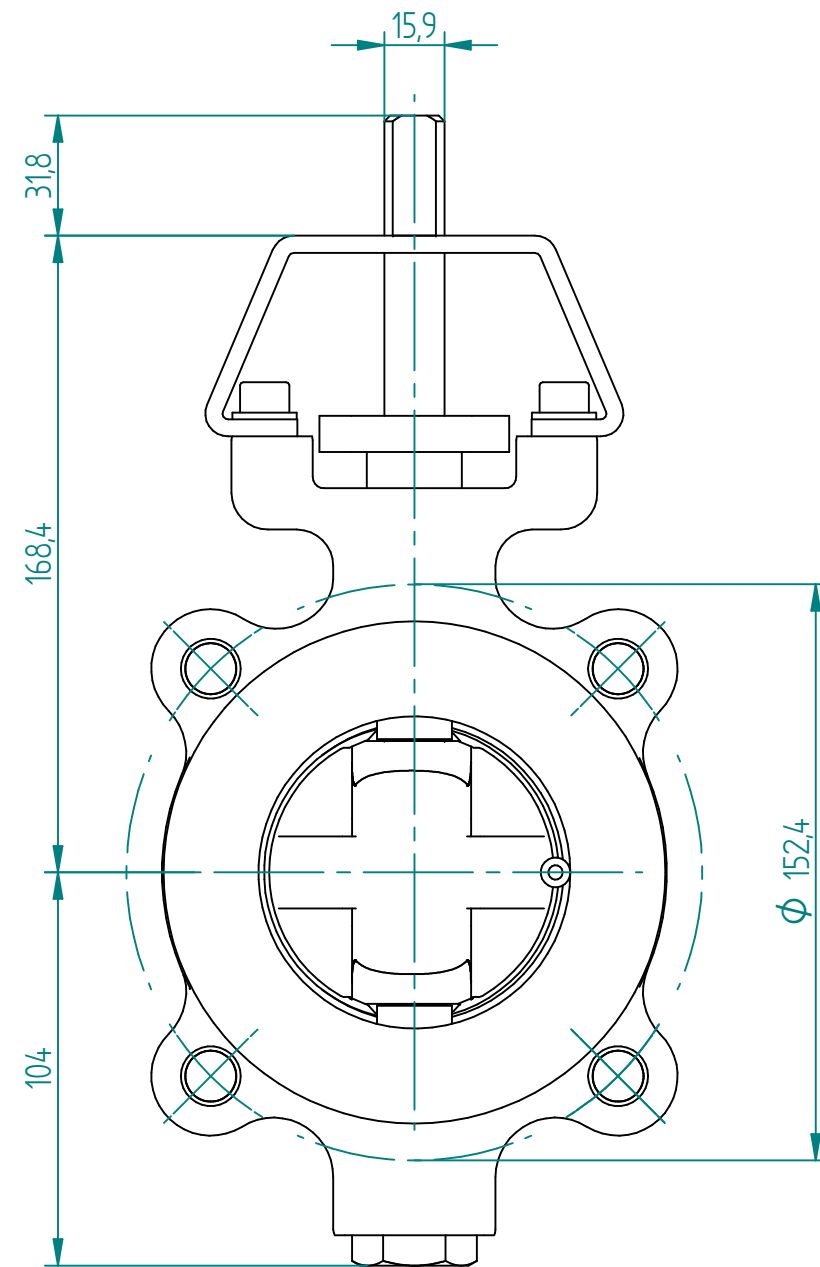

1:2 Mounting Plate

	NAME	MOTO	DATE	16.01.2017	SIZE	A3	DWG NO	BRA02436D
	DRAWN	TOCO	dd.mm.yyyy		FILE NAME:	BRA02436D.dft		
	CHECKED	TOCO	dd.mm.yyyy		SCALE:	1:2	REV:	.....
	ENG APPR	TOCO	dd.mm.yyyy		WEIGHT:	7,00 kg	SHEET:	1 OF 1
MGR APPR	TOCO	dd.mm.yyyy						

UNLESS OTHERWISE SPECIFIED DIMENSIONS ARE IN MILLIMETERS AND TOLERANCES ARE +/-0,5

REV	DESCRIPTION	DATE	APPROVED
REVISION HISTORY			

TITLE BUTTERFLY VALVE BRAY S41/01R DOUBLE ECCENTRIC LUG 3" PN16