

No.	Part Name	Material	Qty.
1	Body	Ductile Iron	1
2	Disc	Aluminum Bronze	1
3	Stem	Monel	1
4	Seat	BUNA-N	1

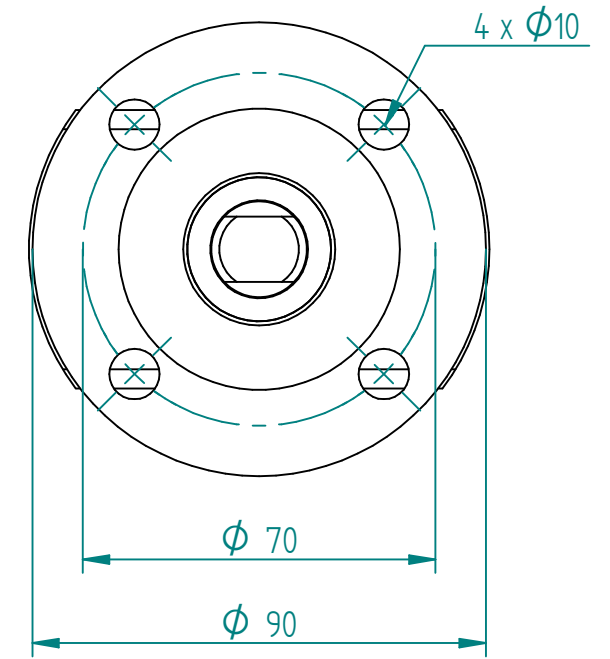

1:1,5 Top Plate

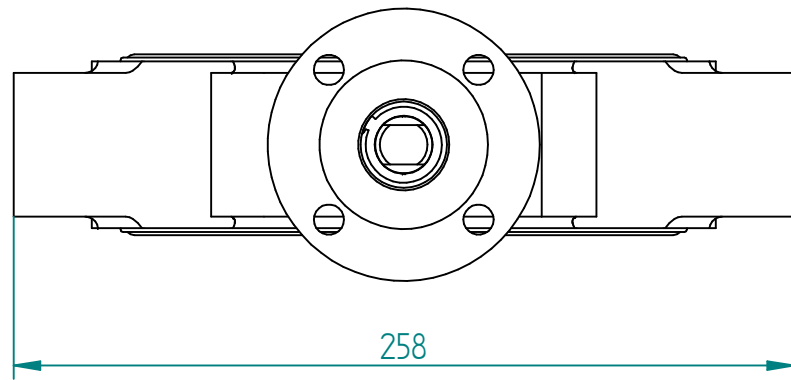

		NAME	DATE	SIZE	DWG NO
DRAWN		MOTO	06.08.2014	A3	BRA00205C
CHECKED		TOCO	dd.mm.yyyy	FILE NAME: S31-DN150.dft	
ENG APPR		TOCO	dd.mm.yyyy	SCALE: 1:2,5	REV:
MGR APPR		TOCO	dd.mm.yyyy	WEIGHT: 10,0 kg	SHEET: 3 OF 3

UNLESS OTHERWISE SPECIFIED DIMENSIONS ARE IN MILLIMETERS AND TOLERANCES ARE +/-0,5

REV	DESCRIPTION	DATE	APPROVED
REVISION HISTORY			

TITLE BUTTERFLY VALVE BRAY S31/T3D4 COCENTRIC LUG 6" PN16