

No.	Part Name	Material	Qty.
1	Body	Ductile Iron	1
2	Disc	Aluminum Bronze	1
3	Stem	Stainless Steel	1
4	Seat	BUNA-N	1

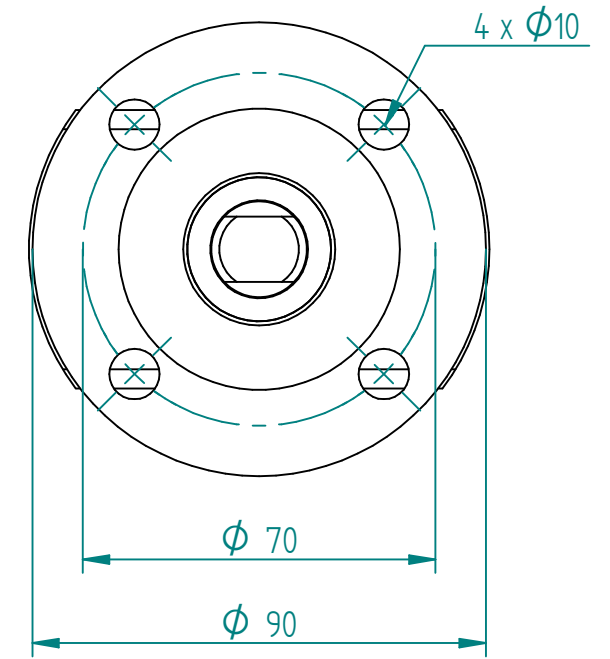
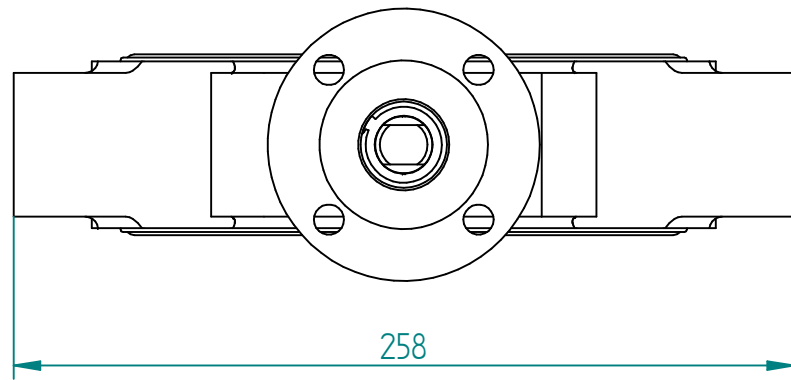

1:1,5 Top Plate

		NAME	DATE	SIZE	DWG NO
	DRAWN	MOTO	06.08.2014	A3	BRA00205
	CHECKED	TOCO	dd.mm.yyyy	FILE NAME: S31-DN150.dft	
	ENG APPR	TOCO	dd.mm.yyyy	SCALE: 1:2,5	REV:
	MGR APPR	TOCO	dd.mm.yyyy	WEIGHT: 10,0 kg	SHEET: 1 OF 1
TITLE	BUTTERFLY VALVE BRAY S31/T35V COCENTRIC LUG 6" PN10				

UNLESS OTHERWISE SPECIFIED DIMENSIONS ARE IN MILLIMETERS AND TOLERANCES ARE +/-0,5

REV	DESCRIPTION	DATE	APPROVED
REVISION HISTORY			