

DETAIL A

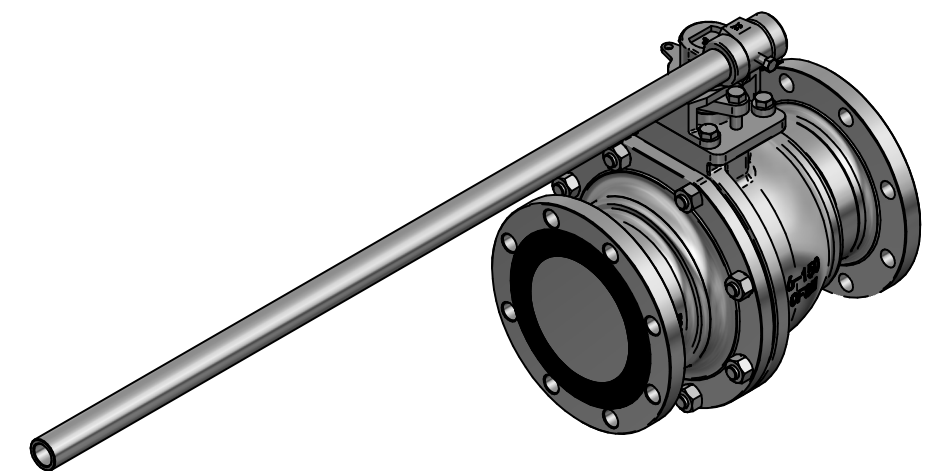

Part name	Material
Body	ASTM A351 Gr CF8M
Seat	TFM1600
Ball	ASTM A351 Gr CF8M
Body Stud	ASTM A193 B8
Body Nut	ASTMA194 Gr 8
Stem	ASTM A479 Type 316
Thrust Washer Protector	PEEK
Thrust Washer	Tek-Fil
Stem Bearing	15% RPTFE
Stem Packing	Graphite
Packing Protector	PEEK
Packing Gland	ASTM A167 Type 304
Packing Follower	ASTM A351 Gr CF8M
Gland Bolt	SS304
Travel Stop Housing	CF8M
Housing Bolt	SS304
Travel Stop Plate	SS304
Snap Ring	Nickel Plated Carbon Steel
Handle	Ductile Iron
Handle Bolt	Carbon Steel

Stainless Steel with Lever 2 1/2"-12"

KV	Torque
4325	367 nm



TITLE 2PC BALL VALVE F15-SSJG ANSI150 6" FLANGED  
F-BORE FLOATING CF8M/316/TFM F12 DD26X44  
FIRESAFE W/LEVER B16.10 L-394MM

	NAME	DATE	SIZE	DWG NO
DRAWN	EMLA	29.12.2023	A3	BRA00011C
CHECKED	EMLA	29.12.2023	FILE NAME: BRA00011C.dft	
ENG APPR			SCALE: 1:5	REV: 01
MGR APPR			WEIGHT: 71 kg	SHEET: 1 OF 1

UNLESS OTHERWISE SPECIFIED  
DIMENSIONS ARE IN MILLIMETERS  
AND TOLERANCES ARE +/-0,5

REV	DESCRIPTION	DATE	APPROVED
01	ADDED LEVER	07.09.2024	EMLA
00	ISSUED	12.07.2024	EMLA
REVISION HISTORY			