

DETAIL A

Part name	Material
Body	EN 1.4408
Seat	TFM1600
Ball	EN 1.4401
Body Stud	A2-70 / SS304
Body Nut	A2-70 / SS304
Stem	EN 1.4401
Thrust Washer Protector	PEEK
Thrust Washer	Tek-Fil
Stem Bearing	15% RPTFE
Stem Packing	Graphite
Packing Protector	PEEK
Packing Gland	EN 1.4301 / SS304
Packing Follower	En 1.4408
Gland Bolt	A2-70 / SS304
Travel Stop Housing	EN 1.4408
Housing Bolt	A2-70 / SS304
Travel Stop Plate	A2-70 / SS304
Snap Ring	SS304
Handle	Ductile Iron
Handle Bolt	Carbon Steel

Stainless Steel with Lever DN65-DN300

KV	Torque
4325	367 nm

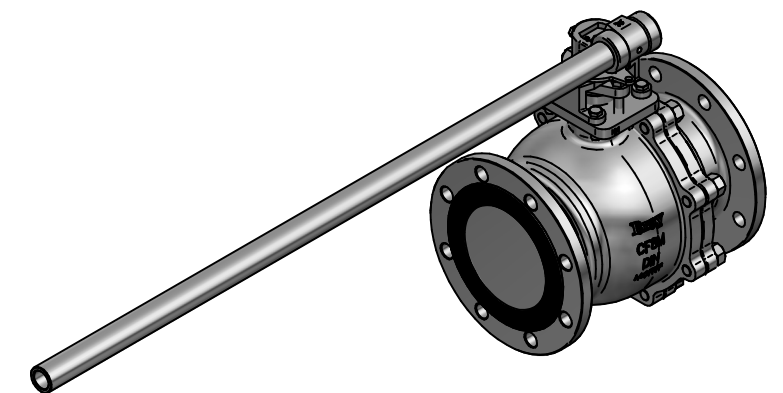

TITLE 2PC BALL VALVE F15-4YJG PN16 DN150 FLANGED F-BORE FLOATING 316/316/TFM 85X85 DD26X42 FIRESAFE W/LEVER DIN3202-F5 L-350MM

	NAME	DATE	SIZE	DWG NO
DRAWN	EMLA	28.12.2023	A3	BRA00011
CHECKED	EMLA	28.12.2023	FILE NAME: BRA00011.dft	
ENG APPR			SCALE: 1:5	REV: 00
MGR APPR			WEIGHT: 76,5 kg	SHEET: 1 OF 1

UNLESS OTHERWISE SPECIFIED DIMENSIONS ARE IN MILLIMETERS AND TOLERANCES ARE +/-0,5

REV	DESCRIPTION	DATE	APPROVED
01	ADDED LEVER	07.09.2024	EMLA
00	ISSUED	12.07.2024	EMLA

REVISION HISTORY