

DETAIL A

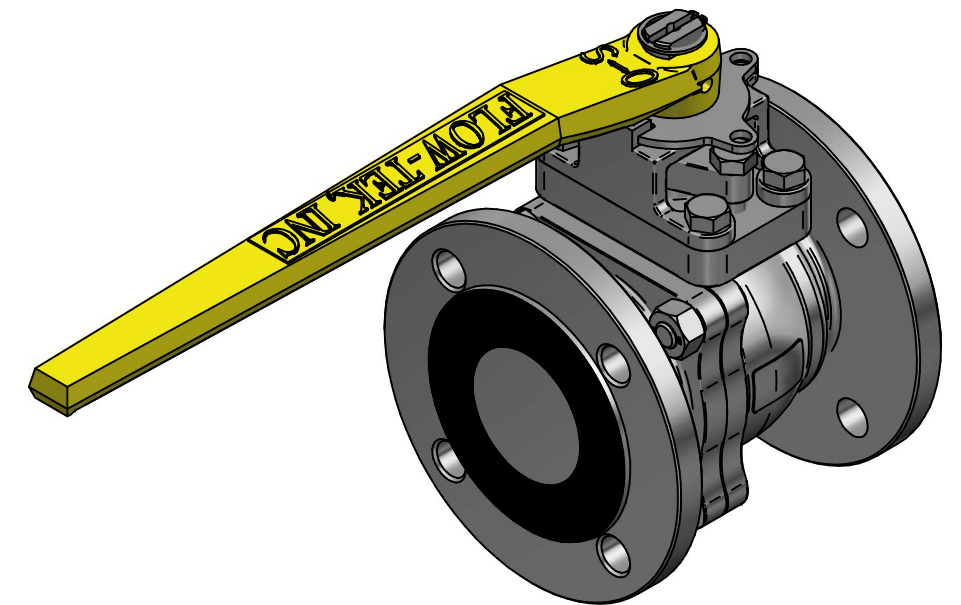

Part name	Material
Body	EN 1.4408
Body Stud	A2-70 / SS304
Seat	TFM1600
Ball	EN 1.4401
Stem	EN 1.4401
Thrust Washer Protector	PEEK
Thrust Washer	Tek-Fil
Stem Bearing	15% RPTFE
Stem Packing	Graphite
Packing Protector	PEEK
Packing Gland	EN 1.4301 / SS304
Packing Follower	En 1.4408
Gland Bolt	A2-70 / SS304
Travel Stop Housing	EN 1.4408
Housing Bolt	A2-70 / SS304
Travel Stop Plate	A2-70 / SS304
Snap Ring	SS304
Handle	Ductile Iron
Handle Bolt	Carbon Steel

Stainless Steel with Lever DN65-DN300

KV	Torque
675	56 nm



DRAWN	NAME	DATE	SIZE	DWG NO
	EMLA	27.12.2023	A3	BRA00007
CHECKED	EMLA	27.12.2023	FILE NAME: BRA00007.dft	
ENG APPR			SCALE: 1:5	REV: 01
MGR APPR			WEIGHT: 14,5 kg	SHEET: 1 OF 1

TITLE 2PC BALL VALVE F15-4YJG PN16 DN65 FLANGED
F-BORE FLOATING 316/316/TFM 90X47.6 DD17X28
FIRESAFE W/LEVER DIN3202-F4 L-170MM

UNLESS OTHERWISE SPECIFIED
DIMENSIONS ARE IN MILLIMETERS
AND TOLERANCES ARE +/-0,5

REV	DESCRIPTION	DATE	APPROVED
01	ADDED LEVER	28.08.2024	EMLA
00	ISSUED	12.07.2024	EMLA

REVISION HISTORY