

DETAIL A

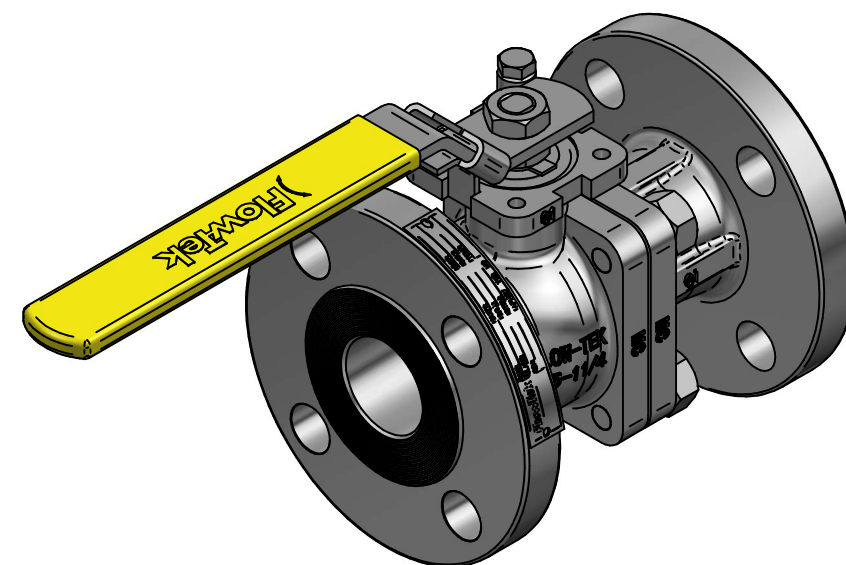

Part name	Material
Body	ASTM A351 Gr CF8M
End Cap	ASTM A351 Gr CF8M
Ball	ASTM A351 Gr CF8M
Seat	TFM 1600
Stem	ASTM A479 Type 316
Body Seal	Spiral Wound 316 with Graphite
Body Nut	ASTM A194 Gr 8
Body Stud	ASTM A193 B8
Anti-Static Device	SS304
Packing Protector	PEEK
Thrust Washer Protector	PEEK
Thrust Washer	Tek-Fil®
Stem Packing	RPTFE or Graphite
Packing Gland	ASTM A167 Type 304
Belleville Washer	SS301
Tab Lock Washer	SS304
Travel Stop Sleeve	ASTM A167 Type 304
Travel Stop Bolt	SS304
Handle	SS304
Lock Nut	ASTM A167 Type 304
Handle Sleeve	Vinyl
Locking Device	SS304
Stainless Steel with Lever 1/2"-2"	

KV	Torque
171	20 nm



TITLE 2PC BALL VALVE F15-SSJG ANSI150 1 1/4" FLANGED F-BORE FLOATING CF8M/316/TFM F05 DD8X11 FIRESAFE W/LEVER B16.10 L-140MM

	NAME	DATE	SIZE	DWG NO
DRAWN	EMLA	28.12.2023	A3	BRA00004C
CHECKED	EMLA	28.12.2023	FILE NAME: BRA00004C.dft	
ENG APPR			SCALE: 1:2	REV: 00
MGR APPR			WEIGHT: 7.5 kg	SHEET: 1 OF 1

UNLESS OTHERWISE SPECIFIED DIMENSIONS ARE IN MILLIMETERS AND TOLERANCES ARE +/-0,5

REV	DESCRIPTION	DATE	APPROVED
01	ADDED LEVER	15.08.2024	EMLA
00	ISSUED	12.07.2024	EMLA
REVISION HISTORY			