

DETAIL A

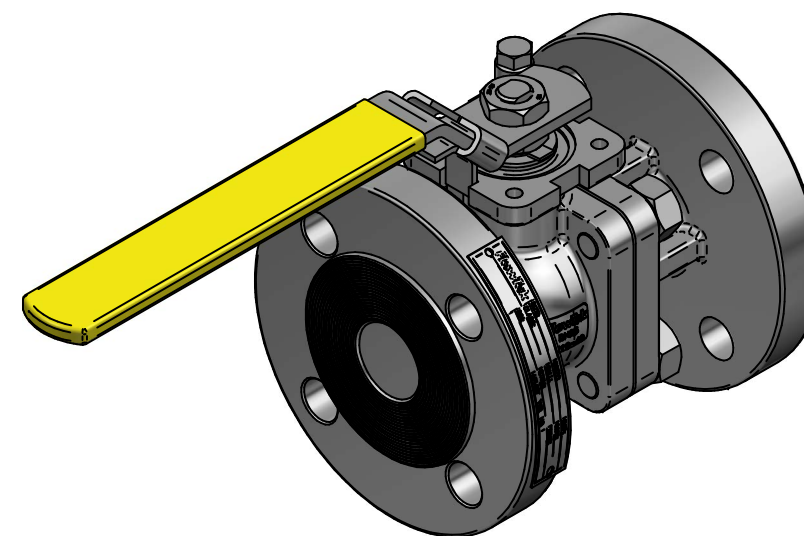

| Part name | Material |
|-------------------------|--------------------------------|
| Body | EN 1.4408 |
| End Cap | EN 1.4408 |
| Ball | EN 1.4401 |
| Seat | TFM 1600 |
| Stem | EN 1.4401 |
| Body Seal | Spiral Wound 316 with Graphite |
| Body Nut | A2-70/Stainless Steel 304 |
| Body Stud | A2-70/Stainless Steel 304 |
| Anti-Static Device | Stainless Steel 316 |
| Packing Protector | PEEK |
| Thrust Washer Protector | PEEK |
| Thrust Washer | Tek-Fil® |
| Stem Packing | RPTFE or Graphite |
| Packing Gland | EN 1.4301/ Stainless Steel 304 |
| Belleville Washer | Stainless Steel 301 |
| Tab Lock Washer | Stainless Steel 304 |
| Travel Stop Sleeve | EN 1.4031/SS304 |
| Travel Stop Bolt | A2/Stainless Steel 304 |
| Handle | Stainless Steel 304 |
| Lock Nut | A2/Stainless Steel 304 |
| Handle Sleeve | Vinyl |
| Locking Device | A2/Stainless Steel 304 |

Stainless Steel with Lever DN15-DN50 & 1/2"-2"

| KV | Torque |
|----|--------|
| 91 | 12 nm |



TITLE 2PC BALL VALVE F15-4YJG PN16 DN25 FLANGED
F-BORE FLOATING 316/316/TFM F05 DD8X12
FIRESAFE W/LEVER DIN3202-F4 L-125MM

| | NAME | DATE | SIZE | DWG NO |
|----------|------|------------|-------------------------|---------------|
| DRAWN | EMLA | 27.12.2023 | A3 | BRA00003 |
| CHECKED | EMLA | 27.12.2023 | FILE NAME: BRA00003.dft | |
| ENG APPR | | | SCALE: 1:2 | REV: 00 |
| MGR APPR | | | WEIGHT: 5,0 kg | SHEET: 1 OF 1 |

UNLESS OTHERWISE SPECIFIED
DIMENSIONS ARE IN MILLIMETERS
AND TOLERANCES ARE +/-0,5

| REV | DESCRIPTION | DATE | APPROVED |
|-----|-------------|------------|----------|
| 01 | ADDED LEVER | 14.08.2024 | EMLA |
| 00 | ISSUED | 12.07.2024 | EMLA |

REVISION HISTORY