

DETAIL A

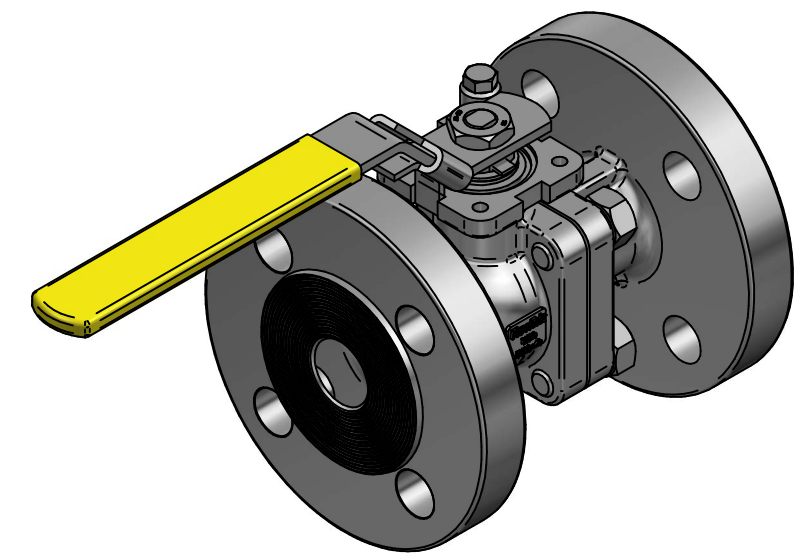

Part name	Material
Body	EN 1.4408
End Cap	EN 1.4408
Ball	EN 1.4401
Seat	TFM 1600
Stem	EN 1.4401
Body Seal	Spiral Wound 316 with Graphite
Body Nut	A2-70/Stainless Steel 304
Body Stud	A2-70/Stainless Steel 304
Anti-Static Device	Stainless Steel 316
Packing Protector	PEEK
Thrust Washer Protector	PEEK
Thrust Washer	Tek-Fil®
Stem Packing	RPTFE or Graphite
Packing Gland	EN 1.4301/ Stainless Steel 304
Belleville Washer	Stainless Steel 301
Tab Lock Washer	Stainless Steel 304
Travel Stop Sleeve	EN 1.4031/SS304
Travel Stop Bolt	A2/Stainless Steel 304
Handle	Stainless Steel 304
Lock Nut	A2/Stainless Steel 304
Handle Sleeve	Vinyl
Locking Device	A2/Stainless Steel 304

Stainless Steel with Lever DN15-DN50 & 1/2"-2"

KV	Torque
52	8 nm



TITLE 2PC BALL VALVE F15-4YJG PN16 DN20 FLANGED  
F-BORE FLOATING 316/316/TFM F04 DD6.3X10  
FIRESAFE W/LEVER DIN3202-F4 L-120MM

	NAME	DATE	SIZE	DWG NO
DRAWN	EMLA	27.12.2023	A3	BRA00002
CHECKED	EMLA	27.12.2023	FILE NAME: BRA00002.dft	
ENG APPR			SCALE: 1:2	REV: 00
MGR APPR			WEIGHT: 4,0 kg	SHEET: 1 OF 1

UNLESS OTHERWISE SPECIFIED DIMENSIONS ARE IN MILLIMETERS AND TOLERANCES ARE +/-0,5

REV	DESCRIPTION	DATE	APPROVED
01	ADDED LEVER	14.08.2024	EMLA
00	ISSUED	12.07.2024	EMLA
REVISION HISTORY			