

## Features

- Compact spool valve convertible from 3/2 to 5/2
- NAMUR mount construction
- Standard manual operator
- DIN, Watertight and Explosionproof solenoids available
- Single and dual solenoid constructions
- Mountable in any position
- Vents air from spring side of actuator to prevent corrosion of actuator

## Construction

Valve Parts in Contact with Fluids	
Body	Black Anodized Aluminum
Spring	Phosphate treated black steel
Shading Coil	Copper
Seals	NBR + PUR
Core and Core Tube	Stainless Steel / Brass
End Covers and Plate	6/6 glass filled PA/FV
Spool	Aluminum
Internal Parts	Zamak, Steel, CA

## Electrical

Standard Coil and Class of Insulation	Enclosure Type	Watt Rating and Power Consumption				Spare Coil Part Number	
		DC Watts	AC Watts	VA Holding	VA Inrush	AC	DC
F	SC	3	2.5	3.5	6	400125	400125
F	SC	6.9	5	7	15	43004649	43004647
F	EF	6.9	6.3	7	10.1	266762	270007
F	WT	6.9	6.3	7	10.1	266763	270008

**Standard Voltages:** SC: 24, 120, 240 Volts AC, 50-60 Hz; 12, 24, 120 Volts DC.  
 WT and EF: 24/50-60HZ, (120/60, 110-120/50)①, (240/60, 220-240/50)② Volts AC;  
 6, 12, 24, 120 Volts DC.  
 ① Order as 120/60, 110/50  
 ② Order as 240/60, 220/50

## Solenoid Enclosures

**Standard: - Prefix**

**SC** = IP65 type DIN (open frame) per 46244

**WT** = Combination General Purpose and Watertight Types 1, 2, 3, 3S, 4, and 4X

**EF** = Combination Explosionproof and Watertight Types 3, 3S, 4, 4X, 6, 5P, 7, 9 Class I, Div. 1 (Groups A - D) and Class II, Div. 1 Type 9 (Groups E-G)

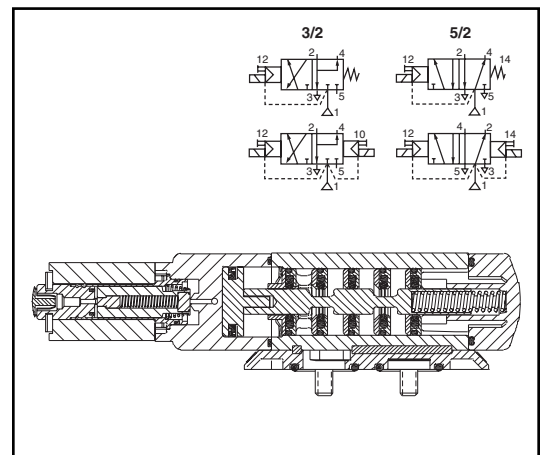

VALVE AUTOMATION

## Nominal Ambient Temp. Ranges

**SC:** AC/DC: 5°F to +140°F (-15°C to 60°C)

**EF:** AC: 5°F to +104°F (-15°C to 40°C)

DC: 5°F to +77°F (-15°C to 25°C)

**WT:** AC: 5°F to +140°F (-15°C to 60°C)

DC: 5°F to +77°F (-15°C to 25°C)

**Note:** For temperatures below 32°F (0°C) moisture-free air must be used.

Refer to Engineering Section for details.

## Approvals

**SC** (2.5W and 3W only) UL recognized component, CSA certified.

**WT:** UL recognized component, CSA certified.

**EF:** UL and CSA listed solenoid.

Meets applicable CE directives.

SIL 3 capable per IEC 61508 on normally closed single solenoid. Third party certification provided by EXIDA.

Refer to Engineering Section for details.

**Specifications (English units)**

Pipe Size (ins.)	Orifice Size (ins.)	Cv Flow Factor	Operating Pressure Differential (psi)		Fluid Temperature °F (for single and dual solenoid)			Single Solenoid PFD <sub>AVG</sub> = 3.3 x 10 <sup>-3</sup>	Dual Solenoid	Const. Ref.	Watt Rating/ Class of Coil Insulation	
			Min.	Max.	Min.	Max. AC	Max. DC	Catalog Number	Catalog Number		AC	DC
<b>OPEN FRAME DIN COIL</b>												
1/4 ①	1/4	.86	30	150	5	140	140	SC8551A001MS	SC8551A002MS	1	2.5	3
1/2	1/2	3.7	30	150	-15	140	140	SC8553A001MS	SC8553A002MS	2	5	6.9
<b>WATERTIGHT ENCLOSURE</b>												
1/4 ①	1/4	.86	30	150	5	140	77	WT8551A001MS	WT8551A002MS	1	6.3	6.9
1/2	1/2	3.7	30	150	-15	140	77	WT8553A001MS	WT8553A002MS	2	6.3	6.9
<b>EXPLOSIONPROOF ENCLOSURE</b>												
1/4 ①	1/4	.86	30	150	5	104	77	EF8551A001MS	EF8551A002MS	1	6.3	6.9
1/2	1/2	3.7	30	150	-15	104	77	EF8553A001MS	EF8553A002MS	2	6.3	6.9

① 1/8 inch NPT exhausts.

**Specifications (Metric units)**

Pipe Size (ins.)	Orifice Size (mm)	Kv Flow Factor (m3/h)	Operating Pressure Differential (bar)		Fluid Temperature °C (for single and dual solenoid)			Single Solenoid PFD <sub>AVG</sub> = 3.3 x 10 <sup>-3</sup>	Dual Solenoid	Const. Ref.	Watt Rating/ Class of Coil Insulation	
			Min.	Max.	Min.	Max. AC	Max. DC	Catalog Number	Catalog Number		AC	DC
<b>OPEN FRAME DIN COIL</b>												
1/4 ①	6.4	.7	2	10	-15	60	60	SC8551A001MS	SC8551A002MS	1	2.5	3
1/2	13	3.15	2	10	-25	60	60	SC8553A001MS	SC8553A002MS	2	5	6.9
<b>WATERTIGHT ENCLOSURE</b>												
1/4 ①	6.4	.7	2	10	-15	60	25	WT8551A001MS	WT8551A002MS	1	6.3	6.9
1/2	13	3.15	2	10	-25	60	25	WT8553A001MS	WT8553A002MS	2	6.3	6.9
<b>EXPLOSIONPROOF ENCLOSURE</b>												
1/4 ①	6.4	.7	2	10	-15	40	25	EF8551A001MS	EF8551A002MS	1	6.3	6.9
1/2	13	3.15	2	10	-25	40	25	EF8553A001MS	EF8553A002MS	2	6.3	6.9

① 1/8 inch NPT exhausts.

## Dimensions inches (mm)

Series	8551
NPT	1/4
L1	5.47 (139)
L2	7.56 (192)
H1	1.30 (33)
W	1.77 (45)

**NOTE: Valve shown with CM22  
DIN terminal coil and connector.  
Connector sold separately.**

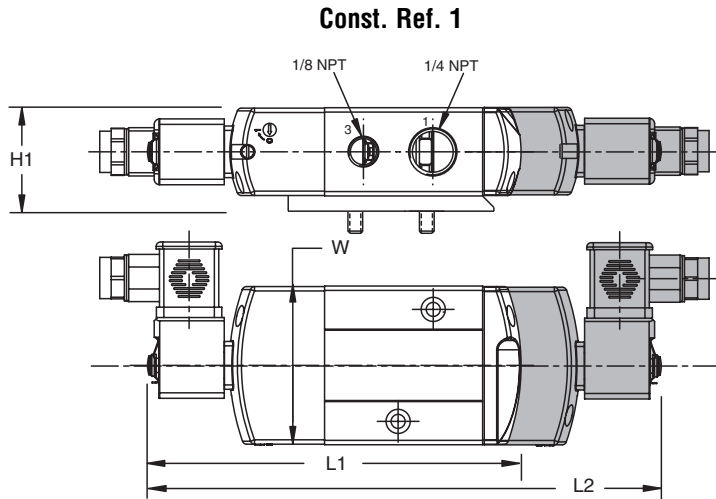

**8551 NAMUR Footprint**

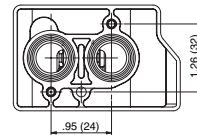

Series	8553
NPT	1/2
L1	7.76 (197)
L2	10.25 (260)
H1	1.94 (49)
W	2.85 (72)

**NOTE: Valve shown with CM22  
DIN terminal coil and connector.  
Connector sold separately.**

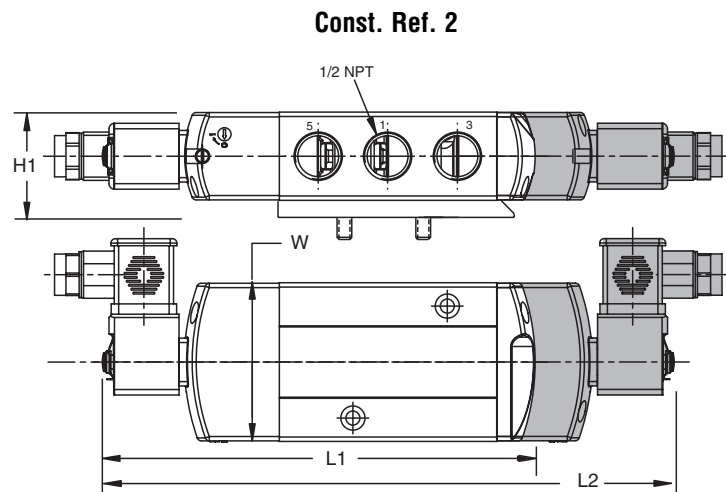

**8553 NAMUR Footprint**

