



# SEMI LUGGED BUTTERFLY VALVE

**DN40-DN1200**

**MODEL NUMBER: BFVSL-S571**



Temp Range	Flange Drilling	Design Standard	Testing
-20°C to +120°C	BS EN1092 PN16	EN593	EN12266

## Application

- For flow control and isolation, widely used for clean and treated water applications

## Features

- Twin shaft design
- Suitable for end of line duty upto 10 bar (up to DN300)
- Compact design with streamlined disc
- High KV/ CV valves
- Vulcanized bonded liner for longer lifetime and lower torque
- ISO EN5211 actuation flange
- ATEX certification



## Options

- Under cut Discs (6 bar- 10 bar)
- Various body, disc, shaft and liners available
- PN10, PN16, PN25, BSTD/E, ANSI connections
- Lever/ gearbox operation
- Torque figures available on request

## Accessories

Position indication, limit switches, locking facility, actuation, chain wheel assemblies, extension spindles, floor pillar

## Materials

No.	Part Name	Material
1	Body	Ductile Iron, carbon steel, stainless steel, duplex, aluminium bronze, Zinc Bronze
2	Disc	Ductile iron 300 um Rilsan coated, aluminium bronze, bronze, stainless steel, duplex, monel
3	Shaft	Stainless steel, duplex, monel (K500), aluminium bronze
4	Liner	NBR, EPDM, VITON

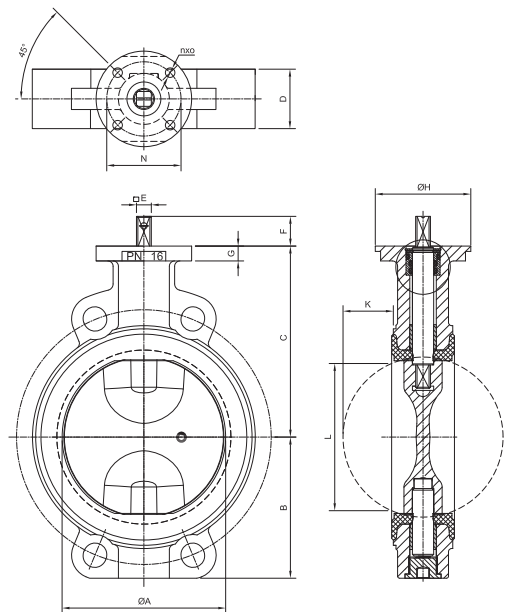

DN40~DN300



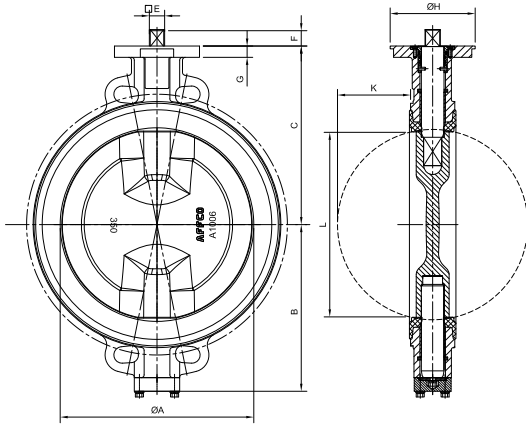
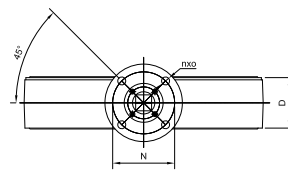
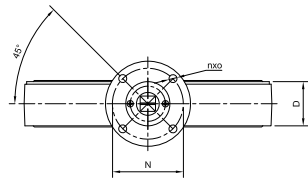

DN350~DN400

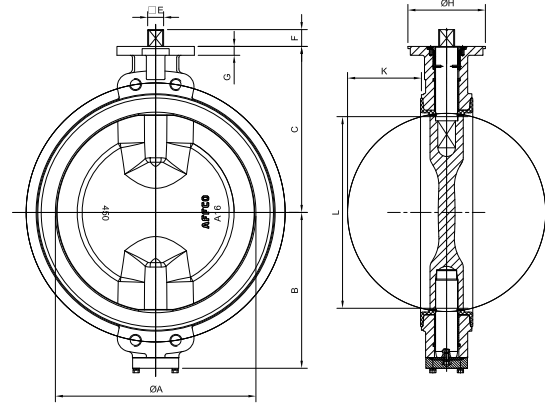

DN350~DN650

## Dimensions

DN	NPS	ØA	E	F	B	C	ØH	D	N(PCD) [ISO 5211]	n x Ø	G	L	K	Weight Appr. (KG)
40	1 1/2"	40	11	25	61	113	90	33	Φ70[F07]	4xΦ9	12	23	3.5	2.2kg
50	2"	50	11	25	67	118	90	43	Φ70[F07]	4xΦ9	12	30	4.7	2.4kg
65	2 1/2"	65	11	25	74	126	90	46	Φ70[F07]	4xΦ9	12	49	11	3.0kg
80	3"	80	11	25	82	133	90	46	Φ70[F07]	4xΦ9	14	68	18	3.8kg
100	4"	102	11	25	100	147	90	52	Φ70[F07]	4xΦ9	14	90	26	4.6kg
125	5"	125	14	28	112	160	90	56	Φ70[F07]	4xΦ9	14	114	35	7.2kg
150	6"	150	14	28	134	180	90	56	Φ70[F07]	4xΦ9	14	140	47	9.5kg
200	8"	200	17	28	159	204	90	60	Φ70[F07]	4xΦ9	14	192	70	13.5kg
250	10"	250	22	30	195	245	125	68	Φ102[F10]	4xΦ11	15	243	91	20.2kg
300	12"	300	22	30	220	270	125	78	Φ102[F10]	4xΦ11	15	293	113	29.6kg
350	14"	336	27	29	282	315	150	78	Φ125[F12]	4xΦ14	20	327	129	39kg
400	16"	400	27	29	307	350	150	102	Φ125[F12]	4xΦ14	20	383	147	70kg
450	18"	450	36	38	352	375	175	114	Φ140[F14]	4xΦ18	20	432	167	98kg
500	20"	500	36	38	387	415	175	127	Φ140[F14]	4xΦ18	20	481	185	128kg
550(PN10)	22"	550	36	38	420	480	210	154	Φ140[F14]	4xΦ18	20	526	198	178kg
550(PN16)	22"	550	46	48	420	480	210	154	Φ140[F14]	4xΦ18	25	526	198	185kg
600	24"	600	46	48	452	465	210	154	Φ165[F16]	4xΦ22	25	581	223	203kg
650	26"	650	46	48	475	530	210	165	Φ165[F16]	4xΦ22	30	621	239	281kg
700(PN10)	28"	700	70	110	502	555	210	165	Φ165[F16]	4xΦ22	25	669	262	270kg
700(PN16)	28"	700	80	120	502	555	300	165	Φ254[F25]	8xΦ18	30	669	262	320kg
800(PN10)	32"	800	80	120	557	620	300	190	Φ254[F25]	8xΦ18	30	767	300	380kg
800(PN16)	32"	800	100	120	557	620	300	190	Φ254[F25]	8xΦ18	30	767	300	430kg
900(PN10)	36"	900	90	120	622	675	300	203	Φ254[F25]	8xΦ18	30	865	343	500kg
900(PN16)	36"	900	110	160	622	675	300	203	Φ254[F25]	8xΦ18	30	865	343	550kg
1000(PN10)	40"	1000	90	120	672	740	300	216	Φ254[F25]	8xΦ18	30	962	385	750kg
1000(PN16)	40"	1000	120	160	672	740	300	216	Φ254[F25]	8xΦ18	30	962	385	825kg
1100(PN10)	44"	1100	105	120	800	756	350	254	Φ298[F30]	8xΦ22	40	1042	410	1021kg
1100(PN16)	44"	1100	125	160	800	756	350	254	Φ298[F30]	8xΦ22	40	1042	410	1120kg
1200(PN10)	48"	1200	110	160	875	824	350	254	Φ298[F30]	8xΦ22	40	1146	410	1250kg
1200(PN16)	48"	1200	130	160	875	824	350	254	Φ298[F30]	8xΦ22	40	1146	410	1370kg

