

LUG TYPE S64



LUG TYPE S64, BONDED LINER

Size DN40 to DN1200

Design EN593

Face to face acc. EN 558.1 series 20

Flange connections DIN PN6-10-16-25

ANSI B 16.5 Cl. 150#

JIS B 2211 5K, 10K

Temperature range -40 / + 250 °C

Various pressure ratings up to 25 bar

Top flange according ISO 5211

Vacuum to 1*10⁻³ 0,2 Torr absolute

LUG TYPE S64

BARE SHAFT

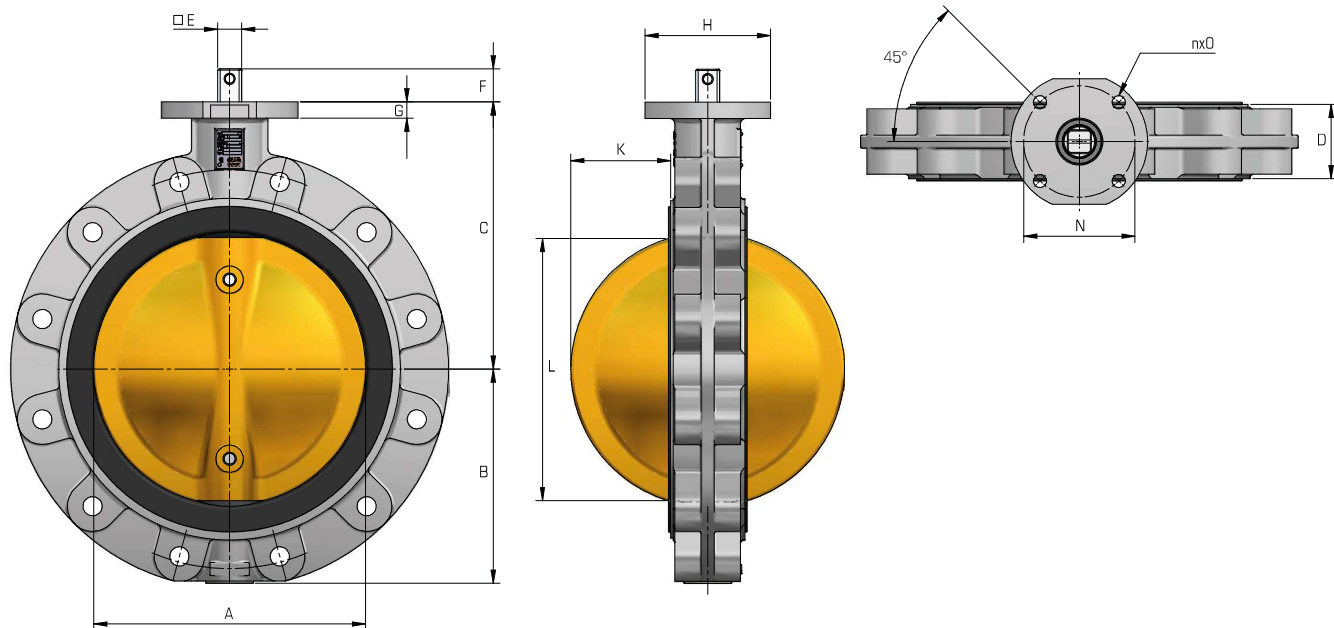

Standard available materials:

Body	Disc	Shaft	Seat
EN-JS1030	BS1400 AB2	SS 1.4122	NBR
A216 WCB	EN-JS1030	SS 431	EPDM
SS 1.4408	SS 1.4408	SS 1.4462	Viton
BS1400 AB2	SD 2507	SD F53	Silicone

DN	NPS	ϕA	E	F	B	C	ϕH	D	N (PCD) (ISO 5211)	n x O	G	L	K	Weight +/-kg
200	8"	201	17	28	159	204	90	60	$\phi 70$ (F07)	4 x $\phi 9$	14	192	70	18,5 kg
250	10"	252	22	30	195	245	125	68	$\phi 102$ (F10)	4 x $\phi 11$	15	243	91	30,3 kg
300	12"	304	22	30	220	270	125	78	$\phi 102$ (F10)	4 x $\phi 11$	15	293	113	48 kg