

Xtreme TORQUE™

STRATEGY

LEAD FROM THE FRONT THROUGH INNOVATION

- Upgrade Product Line to Maintain Market Leadership and Establish Value Differential
- Develop Breakthrough Product & Technology to Set New Industry Standards

2024 ULTRA[®] XT PRODUCT LINE STRATEGY

Provide a Breakthrough Airless Spraying Experience End Users Never Thought Possible

- Breakthrough Motor Technology
- Breakthrough Spray Control & Performance
- Breakthrough Advancements In Pump Technology



INTRODUCING THE BREAKTHROUGH GRACO **XTREME TORQUE™** MOTOR

**REVOLUTIONARY DESIGN
DELIVERS**



**PATENTED TECHNOLOGY
SO INNOVATIVE THAT WE
PURCHASED THE COMPANY**



PATENT PENDING

**DESIGNED.
ENGINEERED.
MANUFACTURED.
BY GRACO.**



ALL MOTORS ARE NOT CREATED EQUAL



MULTIPURPOSE MOTORS

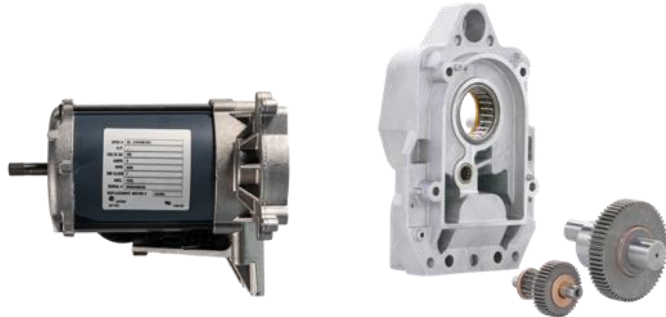

- Requires High RPM, Multistage Gearing For Torque
- Limited Responsiveness Due to High RPM
- Increases Part Count, Noise and Weight

XT MOTORS



- ✓ Achieves Xtreme Torque at Low RPM, No Multistage Gears Needed
- ✓ Low RPM Provides Pinpoint Accuracy for Complete Control
- ✓ Fewer Parts, Quieter Operation, and Lightweight

DID YOU KNOW?

Today's Spray Equipment Uses Same Motors

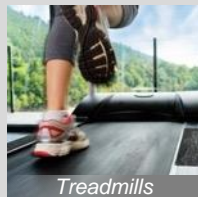

Treadmills



Furnaces



Washers & Dryers

**ONLY MOTOR IN WORLD
DESIGNED FOR
AIRLESS SPRAY**



INTRODUCING THE BREAKTHROUGH GRACO **XTREME TORQUE™** MOTOR



UNMATCHED PERFORMANCE!

PATENT PENDING

- **15X MORE TORQUE**
THAN TRADITIONAL MOTORS
- **8X MORE MAGNETS** DELIVER RAPID
ACCELERATION AND SMOOTH PERFORMANCE
- MONITORING PRESSURE **60X**
PER MOTOR REVOLUTION
- **90% LOWER** RUNNING SPEEDS
- THE **NEW** SOUND OF QUALITY™



**THE INDUSTRY'S MOST POWERFUL MOTOR.
EXCLUSIVELY FROM GRACO.**



UP TO 10X QUIETER



THE SOUND OF QUALITY™



**EXISTING PLATFORM
UP TO 105db**



**XT PLATFORM
UP TO 70db**

“The Quietness Is The Coolest Thing About It. I Can Finally Hear My Radio And It’s Much Easier To Talk To My Guys.”

*William Stanley
Owner, First Class Restoration & Sandblasting*

FIRST THING EVERY END USER NOTICES!



USERS HAVE DIFFICULTY DIALING INTO THE RIGHT PRESSURE

PRESSURE SET **TOO LOW** DELIVERS
LARGE PRESSURE FLUCTUATIONS

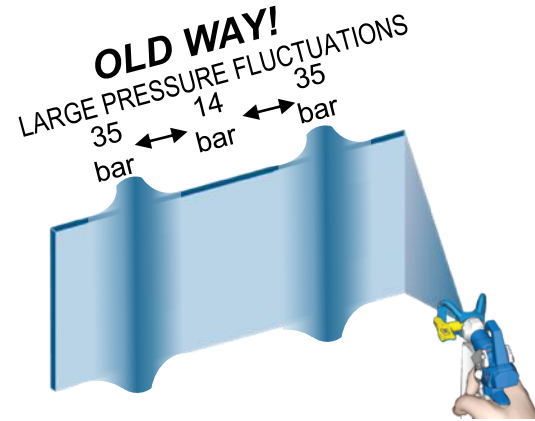

OLD WAY!
INCONSISTENT THICKNESS

PRESSURE SET **TOO HIGH** DELIVERS
LARGE MATERIAL BLAST

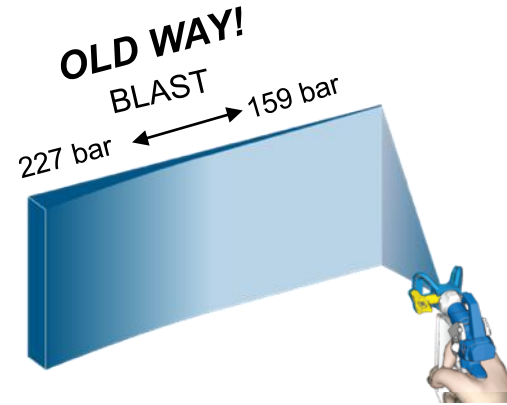

OLD WAY!
INCONSISTENT THICKNESS

CONTRACTORS ARE **UNAWARE**
OF BEST SETUP PRACTICES



INCORRECT PRESSURE SETTING CAN LEAD TO

- ✗ Potential Cracking When Dry
- ✗ Potential for Poor Finish (Runs)
- ✗ More Overspray and Prep Required
- ✗ Excessive Tip and Pump Wear
- ✗ Inconsistent Sheen
- ✗ Inconsistent Mil Build
- ✗ Requiring Added Steps (Backrolling)

NEXT GENERATION CONTROL & FINISH



RAPID-RESPONSE™ PRESSURE CONTROL

PATENT PENDING

INSTANTLY RESPONDS TO DELIVER THE BEST FINISH QUALITY

- Immediately Adjusts For The Steadiest Pressure While Ensuring Seamless Motor Transitions During Pump Changeovers
- Precision Control Lets You Set Preferred Pressure – Without Having To Re-adjust

DELIVERS MORE PERFORMANCE ACROSS FULL TIP SIZE RANGE

WIDEST PERFORMANCE RANGE IN THE INDUSTRY

- Offers The Largest Operating Pressure (Between 3 - 227 bar) To Ensure Full Control And Maximum Productivity
- Spray More Jobs With Breakthrough Airless Control!
- Flexible For Full Application Range - Coatings, Hose Lengths And Tip Sizes To Meet Every Application



RAPID-RESPONSE™
SEE THE DIFFERENCE!



**WORLD'S
STADIEST
RUNNING
PRESSURE
PERIOD**



PUSH-BUTTON PERFORMANCE



SELECTABLE PERFORMANCE MODES™

PATENT PENDING

BUILT TO DELIVER BEST PERFORMANCE AND FINISH FOR EVERY APPLICATION

- Two Selectable Performance Modes Offer Unique Performance Levels To Boost Efficiency on Every Job
- Helps Novice Painters Deliver A Superior Finish – On Day One!
- Expand Capability And Range Of Applications With A Single Sprayer – Like Having Two Sprayers In One!

EASY TO USE.

EASY TO DEMO.

EASY TO SELL!

*SUPERIOR FINISH WITH
THE PUSH OF A BUTTON*



L

**LOW PRESSURE
PERFORMANCE MODE**

H

**HIGH PRESSURE
PERFORMANCE MODE**

NEXT GENERATION CONTROL & FINISH



LOW PRESSURE PERFORMANCE MODE

PATENT PENDING

USE LP PERFORMANCE MODE ON THE FULL RANGE OF COATINGS



**LOW PRESSURE
PERFORMANCE MODE**

BRING ON SAVINGS WITH XTREME PRECISION & CONTROL 3 - 140 BAR

- Easier Than Ever To Spray At Low Pressure With RAC® X LP SwitchTips
– Reduce Overspray, Maximize Life, and Achieve a Perfect Airless Finish at Half the Pressure!
- Dial With Precision and Achieve The Specific Pressure Required For Your Coating – in 1 bar Increments
- For the first time ever - Running and Stall Pressure are almost equal!
- The Full Control Dial Is Finely Tuned To 3 - 140 bar Range, Making It Simpler To Achieve The Exact Pressure Desired, With Revolutionary Control Down To 3 bar.



NEXT GENERATION CONTROL & FINISH



HIGH PRESSURE PERFORMANCE MODE

PATENT PENDING

IDEAL FOR DIFFICULT TO ATOMIZE MATERIALS, EXTENDED HOSE LENGTHS OR DURING COLD RUNNING CONDITIONS

- Delivers Full Performance – Now With The Most Consistent Pressure
- Up To 75% Less Pressure Fluctuations!
- Delivering The Best Finish Quality At Any Pressure Setting
- Achieve The Specific Pressure Required For Coating and Limit Overspray
– Easily adjust In 3 bar Increments

XTREME PERFORMANCE WITH HIGH PRESSURE 35 – 227 BAR

- Use This Mode For The Best Finish With Any RAC® SwitchTip
- Rapid-Response System Maintains The Steadiest Running Pressure – Period!
- Stall Pressure Now Equals Running Pressure – No Need To Overshoot!

H

**HIGH PRESSURE
PERFORMANCE MODE**



PROTECT YOUR INVESTMENT!



WATCHDOG™

PATENTED

- Now On ALL XT Electric Sprayers
- Prevents Pump Damage If The Material Supply Is Too Low By Shutting Off The Pump Automatically
- Automatically Prevents Dry Pumping



Engage WatchDog by Holding Performance Mode Button for 3 seconds

TURBOCLEAN™

PATENT PENDING

- Now On ALL XT Electric Sprayers
- Industry's fastest Pump Cleaning System!
- Drives The Motor At Max Speed To Deliver The High Velocity Flow (Up To 83 bar)
- High-Velocity Fluid Flow Cleans The Pump 6x Faster Using ½ The Fluid
- New Convenient Location At Top Of Pressure Control For Easy Use
- Reduces Need For Water And Minimizes Recycling Fees



Engage TurboClean by By Simply Turning the Pressure Control to Maximum





ALL *XT* MODELS COME WITH AN LED DISPLAY

- Bright, Easy-to-Read LED Display
- Transparent Cover Shields Display From Debris and Overspray
- Quickly Identify Performance Mode Setting
 - Easily Adjust Performance Mode With Push Of A Button
 - H = High Pressure Performance Mode
 - L = Low Pressure Performance Mode
- Shows Pressure Readout, Job/Lifetime Liter Counter And Self Diagnostics

LONGEST LIFE BEFORE SERVICE



ENDURANCE™ VORTEX® PISTON PUMPS - MIDSIZE

PATENT PENDING

LONGEST LIFE IN INDUSTRY!

- 3X Longer Than the Closest Competitor
- Exclusive VMAX Blue Packings Made Of Proprietary Material Delivering Extended Life

NEW QUIKACCESS™ INTAKE

- Shorter Foot Valve Delivers Faster Priming And Easier Access To Inlet Ball
- Knock Off Foot Valve Design Delivers Fast Cleaning And Debris Clearing
- Spray Longer with Reversible Inlet Seat

FEATURED ULTRA XT MODELS



Ultra
490 **XT**



Ultra
495 **XT**



Ultra
650 **XT**

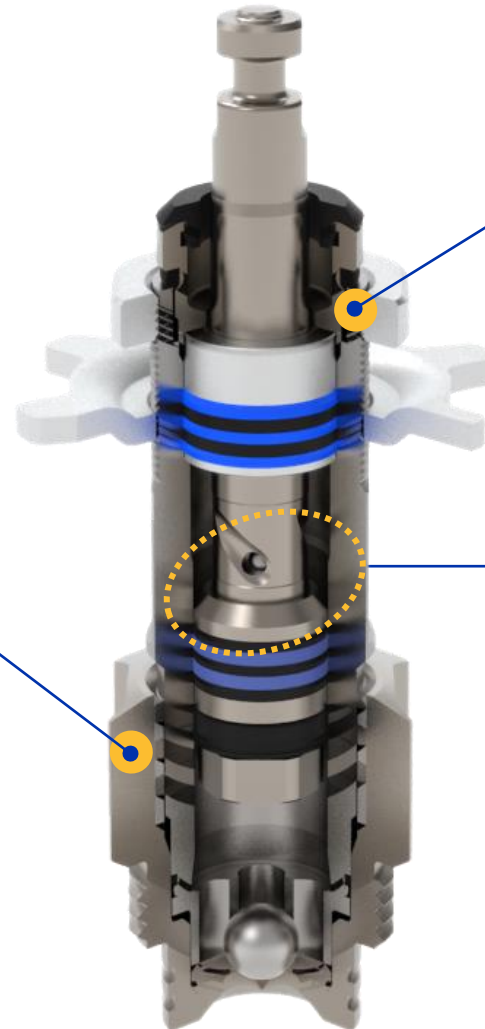

PROCONNECT™ REPLACEMENT SOLUTION

- Fast And Easy On-The-Job Replacement System
- One Part Solution To Keep Spraying

NEW

VORTEX ROTATING ROD TECHNOLOGY

- Automatically Rotates Rod While Pumping Delivering Longest life
- Virtually Eliminates Side Loading

Material Jets
From Rifled
Ports



Piston Rod
Slowly Turns

QUICKLY SERVICE ON JOBSITE



PROCONNECT™ PUMP REPLACEMENT SYSTEM

PATENTED

GRACO KEEPS YOU SPRAYING!

- Proven Small Electric Design Means Same Removal Process For All XT Electric Models
- Eliminate Downtime Waiting For Service
- One-Part Design Means No Pins Or Parts To Lose!

PROVEN SMALL ELECTRIC DESIGN
NOW AVAILABLE ON **ALL XT MODELS**



1 Loosen the Clamping Nut



2 Open Door & Remove Pump



3 Remove Hose & Suction Tube



ULTRA™ 490 - 650 **XT** MIDSIZE ELECTRIC



PATENTED

FEATURES

PATENT PENDING

- NEW** Xtreme Torque™ Motor Technology
- NEW** Rapid-Response™ Pressure Control
- NEW** LED Digital Display
- NEW** Selectable Performance Modes™
- NEW** Quietest Sprayer Ever Built
- NEW** Endurance™ Vortex® Pump With ProConnect™
- NEW** TurboClean™ Cleaning System
- NEW** Watchdog™ Pump Protection
- NEW** Portable, Lighter System
- Easy Out® Pump Filter
- Rugged Durable Frame

MODELS:



Ultra
490 **XT**
.025"
2.6 lpm
Stand, Hi-Boy



Ultra
495 **XT**
.027"
3.0 lpm
Stand, Hi-Boy



Ultra
650 **XT**
.029"
3.4 lpm
Hi-Boy

INCLUDES:

- Contractor™ PC Gun
- RAC X LP517 SwitchTip™
- RAC X Guard
- BlueMax™ II ¼ x 15 m Airless Hose



Xtreme TORQUE™