



GEMU



Solutions for industrial applications



Gert Müller, Managing Partner

GEMÜ Group

Founded in
1964

Over
1800
employees worldwide

6
manufacturing sites

27
sales companies

GEMÜ structure



The GEMÜ Group is a leading manufacturer of valves, measurement and control systems employing over 1800 members of staff worldwide. With six manufacturing sites and 27 subsidiaries, as well as a large network of commercial partners, GEMÜ is now active in over 50 countries on all continents.

Reorganized – for even greater proximity to our customers

With our wide product range, we offer solutions for the most varied customer groups. We work close to the customer in our strategic business units:

- Pharma, Food & Biotech
- Industry
- Semiconductor
- Service
- Medical

The widely positioned modular system and the adapted automation components enable us to combine individualized standard products and customized solutions to create a large number of different configurations and variants.

Table of contents

GEMÜ Group	2	Customized solutions	
GEMÜ Industry	4	Innovation and standard solutions in combination	20
Industry specialization	5–15	Space-saving and multi-functional	
Industrial water treatment	6–7	Multi-port valve blocks for industrial engineering	21
Chemical engineering	8–9	It's all about the right service	22
Power generation and environmental engineering	10–11	Process reliability due to tested quality	23
Mechanical engineering and processing industry	12–13	GEMÜ CONEXO	
Surface finishing	14–15	Electronic identification and	
Overview of our product range		paperless maintenance	24–25
GEMÜ quarter turn valves	16	Product overview	26–28
GEMÜ diaphragm valves and globe valves	17	Worldwide service	29
GEMÜ multi-port valve blocking system and			
solenoid valves	18		
GEMÜ add-on components and accessories	19		

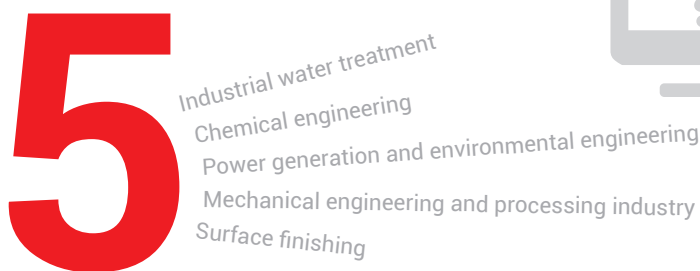

5 areas
 in the Industry Business Unit



Modular system
 Large number of different
 configurations and
 versions possible

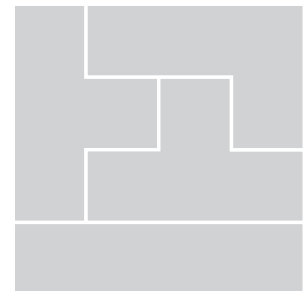

GEMÜ Industry

No other area subjects valves to such a varied range of requirements as those found in industrial applications. Our decades of application experience flow directly into the new and further development of valves. That's why, in this demanding environment, GEMÜ valves have proven very successful to date.

GEMÜ products are used around the globe in water treatment and waste water treatment, the chemical industry, power generation and environmental engineering, the industrial plant and machinery sectors, the paper industry,

the steel and metallurgical industries, mining and metal extraction, surface finishing and in many other areas.

The specific product range includes diaphragm valves, globe and control valves, butterfly valves, ball valves and solenoid valves, each available in metal or plastic versions, as well as accessories for measurement and control systems. The wide range of applications makes GEMÜ valves reliable all-rounders. As customized system solutions, GEMÜ multi-port valve blocks in plastic and metal versions are being used successfully in industrial plant and process engineering.



Industry specialization

Due to the diversity of industrial applications, the Industry business unit has specialized in five main industrial sectors:

- Industrial water treatment
- Chemical engineering
- Power generation and environmental engineering
- Mechanical engineering and processing industry
- Surface finishing



Industrial water treatment

Water is precious – and we supply the technology to handle it responsibly.

The availability of process water plays an important role in industry since virtually every production process requires water. Whether it is for cooling, cleaning or as a starting material for aqueous solutions – depending on the application, unwanted substances must be removed from the raw water or desired substances added. At the same time, industrial processes and the population are dependent upon a safe water supply.

This task is performed by water treatment plants, thus ensuring a functioning circuit. The GEMÜ product range can provide numerous solutions for these plants. We only use carefully selected materials and our quality management system ensures continuous monitoring. External institutes such as the DVGW (German Technical and Scientific Association for Gas and Water), ACS (Certificate of Sanitary Conformity), WRAS (UK Water Regulations Advisory Scheme) and, for applications in the maritime industry, DNV-GL, also testify this quality by awarding certificates.



GEMÜ solutions for water supply, water treatment and recycling

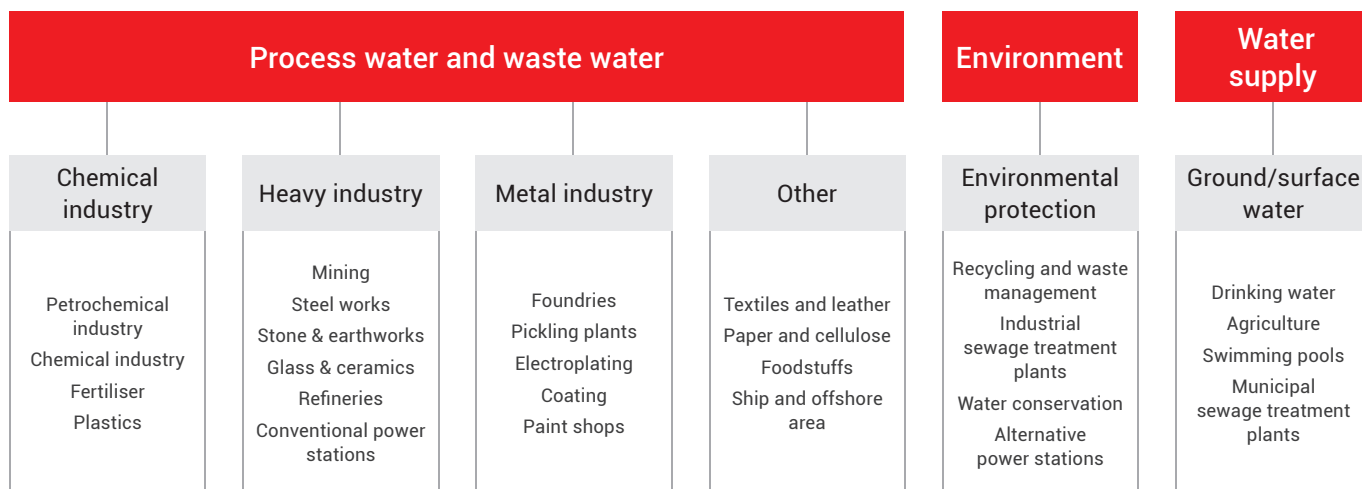

Application example: Treatment of boiler feed water

Not all waters are the same. This is true in particular when foreign matter in the water due to corrosion or the formation of solid precipitates has a negative impact on the heart of a plant or downstream components. For example, there are very high quality requirements of boiler feed water, which is used in process technology or to drive steam turbines. To treat boiler feed water, several water treatment procedures often have to be applied in order to remove suspended matter, ionogenic solutes or dissolved gases. For example, various mechanical procedures are used to remove solids, while solutes are often separated out by ion exchangers. Thermal or chemical degassing can be applied.

Optimal water treatment produces high-quality boiler feed water, thus guaranteeing long-term and damage-free boiler operation.

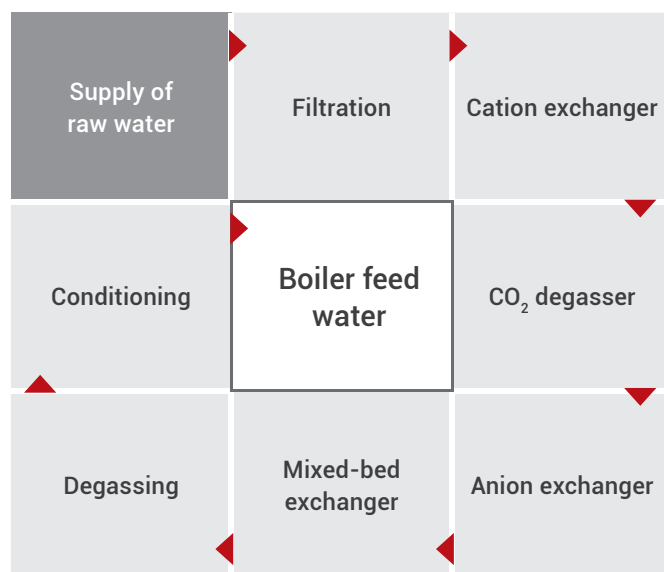



Chemical engineering

All processes under control – including for critical media.

There are stringent requirements for the varied processes in the chemical industry. Whether in the production of fertilisers, paints and varnishes or for applications in fine chemicals – occupational and production safety must be guaranteed.

Specific valve and component solutions are therefore much in demand when dealing with critical working media, high temperatures and high pressures. GEMÜ offers numerous valves made of plastic and high-performance thermoplastics, such as PFA or PVDF. Metal valves with plastic linings are also used successfully in processes with abrasive media and with solid matter. This flexibility regarding material selection ensures maximum process and plant reliability.

GEMÜ solutions for the distribution, handling and dosing of chemicals

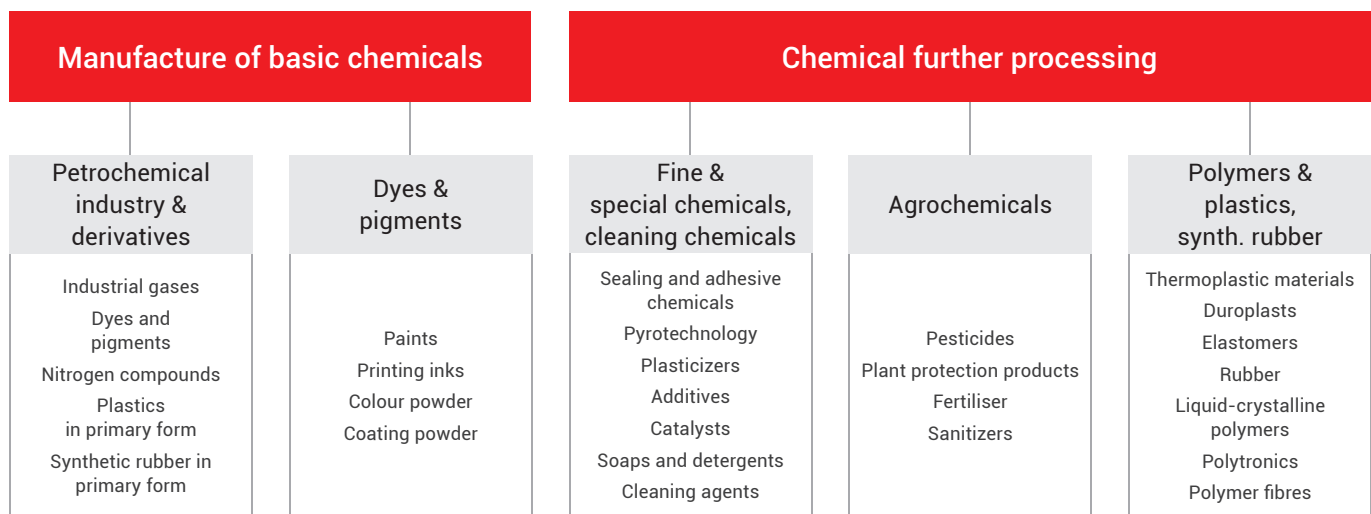

Application example: Production of artificial fertilizers

Today, around 80 per cent of mined phosphorous is processed into fertilizer, because the metabolism of plants, animals and people is familiar with the nutrients released by the mineral fertilisers. In nature, phosphorous occurs only in bound form. Trapped between oxygen atoms, the raw material for artificial fertilizers is extracted from minerals such as apatite, using complex chemical procedures. Through the addition of sulphuric acid and under the influence of high temperatures, by-products are created alongside the super-phosphate fertilizer, such as calcium phosphate and PK, NP and NPK fertilizers. Finally, the fertilizer mixture is concentrated through dehydration and bottled as liquid fertiliser. To produce solid fertilizer, centrifugation is also carried out.

As the quality of phosphorous is increasingly deteriorating due to the high mining output, it is becoming more laborious and thus more expensive to free the raw material of impurities. Reliable and robust components that can sustain critical process steps are therefore all the more important.

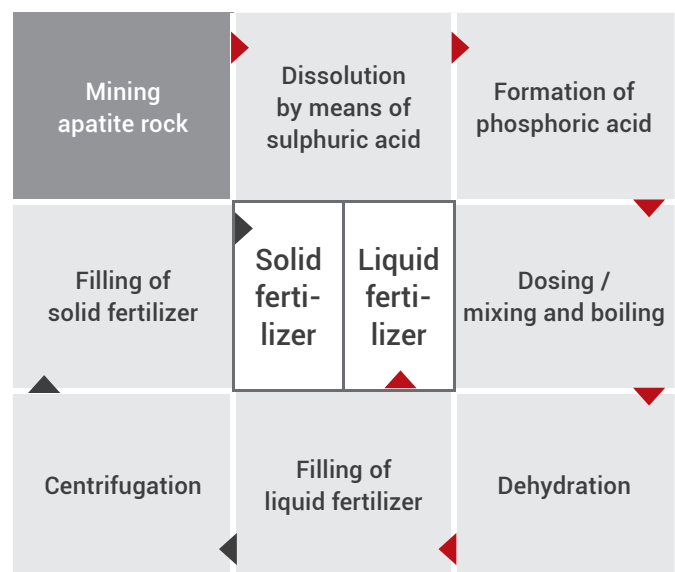



Power generation and environmental engineering

The global energy revolution is in full swing – and we support it fully.

The signs all point towards sustainable modernization of power and heat. We are in the phase of transition yet simultaneously dependent upon conventional energy production. Both centralized and decentralized concepts are used for energy production in the form of hydroelectric power stations, wind power plants, gas turbine power plants and coal power plants. Processes such as the manufacture of biofluids or steam generation also contribute to power generation, while a wide range of storage and thermoprocess technologies ensure energy usage.

Whether renewable or conventional – innovative, efficient and durable products are essential in power generation. That's why, in order to always be able to offer solution-focused concepts, the GEMÜ Group is investing more than 5% of turnover in research and development across the entire range of products each year.

GEMÜ solutions for power generation, storage and use

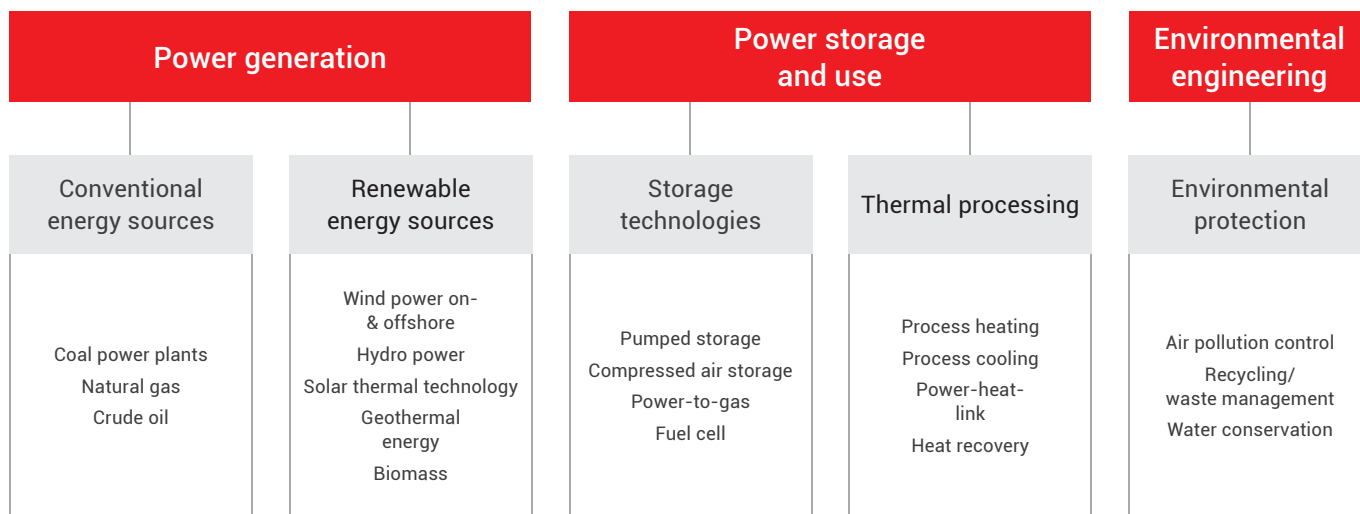

Application example: Production of bioethanol

Bioethanol, as an alternative energy source, has a lot going for it. It's no wonder that procedures to manufacture this natural fuel have been becoming more widespread for some time. With the help of enzymes, the carbohydrates contained in the biomass from starch crops can be fermented into alcohol.

From the pre-treatment of the biomass to fermentation and on to the finished product, procedures for the extraction of bioethanol can be subdivided into different process steps, which each pose different requirements for the technology used in plant engineering.

While particle-rich media determine the valve selection in pre-treatment, parameters such as the conductivity of the substances or operating pressure and temperature are crucial in other process steps.

Specific requirements for the dosing capability of a valve arise, for example, through the addition of water and yeast. GEMÜ understands these requirements and offers the right valve for every process.

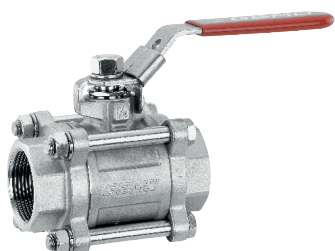
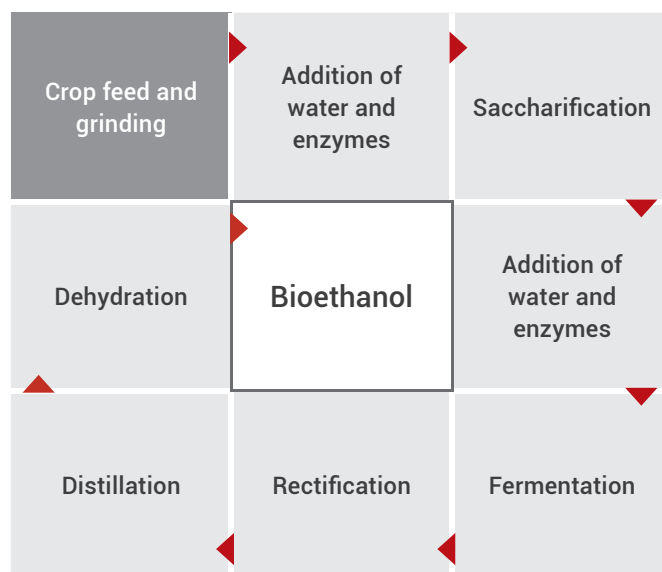



Mechanical engineering and processing industry

A partner for progress, performance and reliability – GEMÜ products work around the globe.

Whether in processing and machine tools, in conveying systems or in printing technology – technological progress is leading to changing procedures and processes both in the mechanical engineering industry and in the processing industry. Growing requirements with regard to automation, documentation and digitalization in particular are playing an increasingly important role.

Robust valves and customized solutions in valve and control systems are part of the GEMÜ product range that is used in cleaning processes for tool moulds or inking units, as well as in the supply of coolants and lubricants in moving machine parts. Also – and in particular – when new requirements arise in plant and mechanical engineering, we are the right partner when it comes to distribution, mixing, supply and isolation of media.

With GEMÜ CONEXO, we are taking a step towards Industry 4.0 and enabling the identification of pipework components, the collection of field data and the optimization of servicing processes and intervals.

GEMÜ solutions for processing machines and machine tools and their manufacture

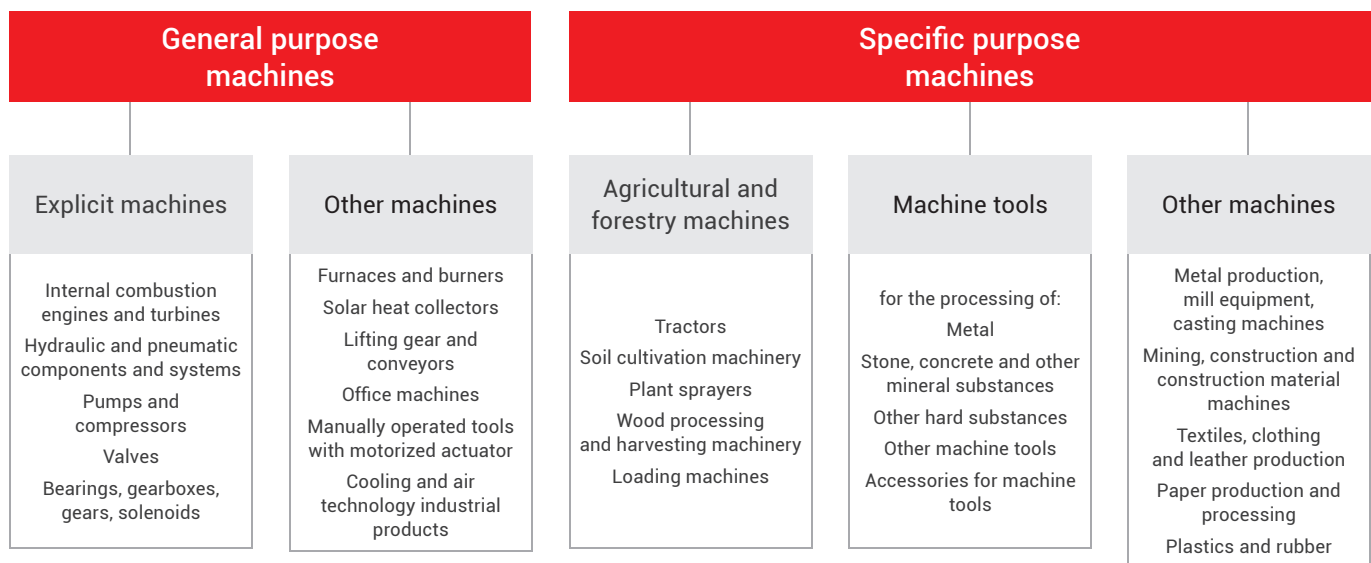

Application example: Handling of cooling lubricant

The use of cooling lubricants is indispensable in chipping and forming manufacturing processes. The aim here is to take suitable measures to largely maintain the properties of water-soluble, non water-soluble and multifunctional oils during their use. The correct handling of the cooling lubricants not only offers economic benefits in the manufacturing process, but also benefits the environment.

The aims of waste reduction and quality assurance are therefore paramount. Standards and directives, such as the Life Cycle Management Act and Water Resources Act, help to achieve these objectives. The plants must be optimally adjusted to the prevailing conditions. This is true in the field of cleaning and treatment as well as in the distribution of the cooling lubricants.

GEMÜ offers the right valve for all requirements, to guarantee gentle yet efficient handling of cooling lubricants. Important issues here include reducing foam formation, separation of substances, corrosion and the handling of mechanical and chemical stresses.

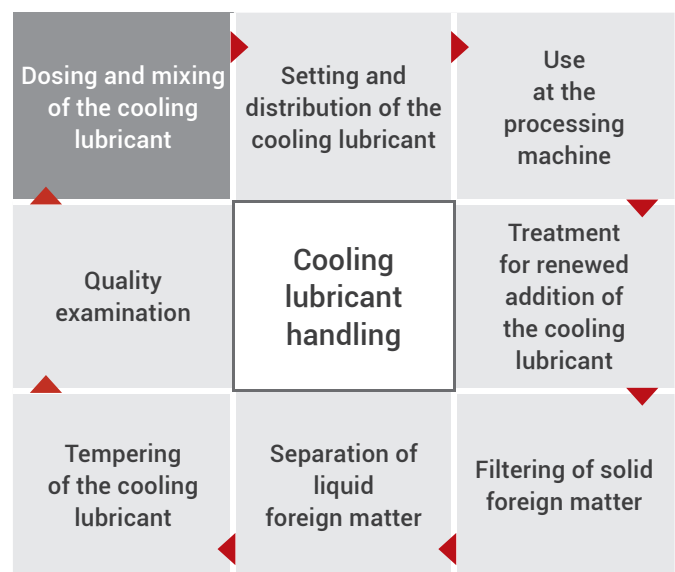



Surface finishing

Technically and optically perfect surfaces – we keep an eye on the special requirements.

Whether a twinkling watch or stainless scaffold in outdoor areas – numerous products today are equipped with high-quality functional or decorative surfaces. While silver-plating or coating processes for paper and fabric are often relied upon for end users, painting and electroplating as well as coating of metals are dominant in industrial applications.

For GEMÜ, high flexibility in material selection for valves is the main factor which keeps ball valves, butterfly valves, globe and control valves and diaphragm valves up to date, even with critical parameters. As an option, valves and individual components such as diaphragms can also be provided free from substances that prevent paint adhesion. These are cleaned accordingly and are packed individually in plastic bags. Furthermore, solely silicone-free lubricants are used during assembly.

GEMÜ solutions for electroplating and painting technology as well as for coating processes

Pre-treatment, intermediate treatment, post-treatment	Mechanical procedures	Chemical/electrochemical procedures		Coating procedures
Cleaning/drying	Grinding, polishing, blasting	Chemical procedures	Electrochemical procedures	Coatings
<ul style="list-style-type: none"> Flushing before the process Flushing after the process Degreasing and cleaning with and without solvents Plasma cleaning Flushing Air drying Drying with dehydrating liquids/mechanical aids 	<ul style="list-style-type: none"> Grinding and polishing agent production Grinding and polishing agent use Production of blasting material Blasting systems Shot-peening Flow grinding 	<ul style="list-style-type: none"> Iron/zinc/manganese-phosphatization Corrosion protection chromate plating Bluing Layers Electro polishing/stripping Hot dipping Chemical metallizing Passivation 	<ul style="list-style-type: none"> Pickling of unalloyed/alloyed steel Non-ferrous metals Zinc and aluminium materials Plastics 	<ul style="list-style-type: none"> Organic coatings Enamelling Metallic thick films Thin film technologies Chemical and anodic oxide coating

Application example: Electro polishing and passivation

Electro polishing and subsequent passivation is a standard process used in many sectors, to make surfaces more resistant and smooth. The surface treatment procedure has the primary purpose of creating a smoother, precise surface to reduce the risk of dirt or product residues accumulating. This increases the promised quality properties of the final product, such as cleanability or simply the visual appearance.

Exact dosing and tempering of the pickling agent and electrolyte is of great importance due to the different requirements for the surface finish.

GEMÜ offers a solution here in all sectors – whether in the field of the plant periphery, e.g. for tempering the baths or for the supply and removal of reagents as well as for the treatment of the media used in the corresponding baths.

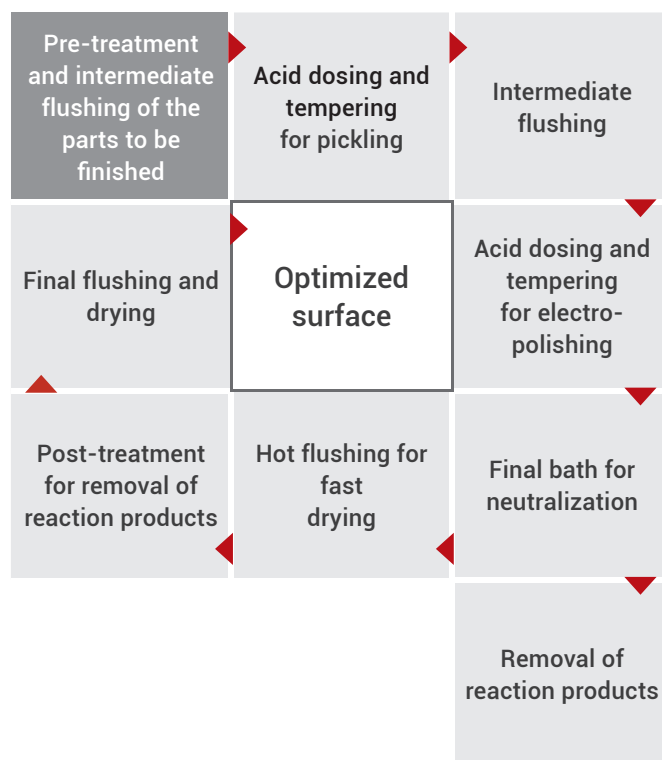

GEMÜ quarter turn valves



Metal butterfly valves

- Available up to DN 1600
- Improved sealing due to special seal geometry – even for larger diameters
- Modular construction
- Extensive applications using a variety of materials
- DVGW approval, FDA, ACS, WRAS and ATEX



Plastic butterfly valves

- Excellent corrosion protection
- Low weight
- Minimal pressure loss
- UV resistant
- Easy installation



Metal butterfly valves with highly resistant seal materials

- High corrosion resistance
- Suitable for high-purity applications
- High temperature resistance
- Can be used for the toughest applications
- Suitable for vacuum



Plastic ball valves

- High flow rates
- Low weight
- Choice of various body materials and connection types
- Available with T or L ball



Metal ball valves

- Low maintenance and reliable spindle sealing
- TA-Luft compliant
- Broad range of operating temperatures and pressures
- Choice of various body materials and connection types

GEMÜ diaphragm valves and globe valves



Metal diaphragm valves

- Suitable for inert, corrosive, liquid and gaseous media
- Insensitive to particulate-carrying media
- Versions according to ATEX on request
- Also available as full bore diaphragm valve



Plastic diaphragm valves

- Flow-optimized, compact design
- Reduced control air consumption
- Varied accessory options
- Extensive applications due to connection and material variety



Metal angle seat globe valves

- Well suited to fast cycle duties and high switching frequencies
- Good flow capability
- Low weight
- Various connections and body materials available
- Comprehensive accessory package



Metal globe valves

- Good control characteristics
- Comprehensive accessory package
- Robust design
- Flanged body in stainless steel or SG iron

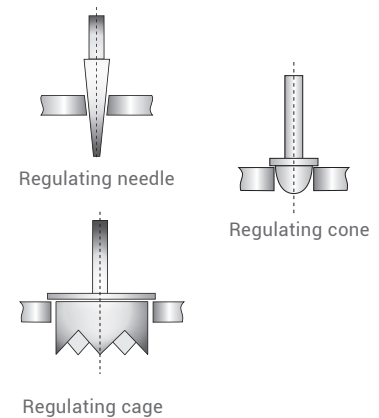

Control bodies

- Design of the control body as needle, cone or cage, depending on nominal size
- Individual design of control valves
- Linear and equal-percentage characteristic curves possible

GEMÜ multi-port valve blocks and solenoid valves



Plastic multi-port valve blocks

- Integration of various functions e.g. filter, pressure sensors, temperature measurements
- Increased plant reliability, fewer fittings, solvent cemented joints
- Space-saving design
- Also available as a modular, extendible unit

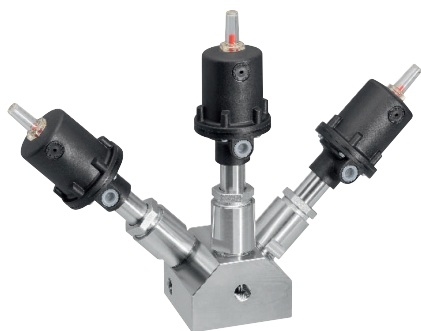

Metal multi-port valve blocks

- Space-saving
- Customized
- Low hold-up volume
- Machined from one block of material



Plastic and metal solenoid valves

- Suitable for clean, liquid and gaseous media
- Designed for fast cycle duties
- Various connections available
- Versions for small (DN 2) and larger nominal sizes (DN 50) are available
- Directly controlled or servo-assisted versions available

GEMÜ add-on components and accessories



Positioners and process controllers

Intelligent positioners and process controllers for linear and quarter turn actuators, remote mounting possible, fast mounting and commissioning due to speed-AP function.

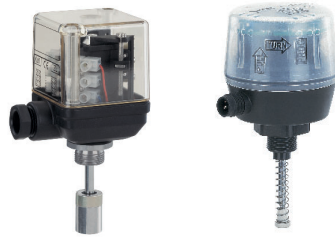

Electrical position indicators

Electrical position indicators in a wide range of versions, manual/automatic stroke adjustment, depending on version also with self-learning speed-AP function, LED display and optional field bus connection.



Intelligent combi switchbox

Combi switchbox for linear actuators, integrated position feedback, manual/automatic stroke adjustment, integrated pilot valve, optional field bus connection.



Pilot valves

Pilot valves for pneumatically operated valves, cylinders and other process components.



Flowmeters

Flowmeters with various functional principles for inert and corrosive liquids and gases. Depending on version, mounting of electrical limit switches and instrument sensors possible as well as field bus connection.



Accessories

Available accessories include stroke limiters and optical position indicators, various mounting kits, control air adapters and NAMUR mounting brackets, plugs and cable connectors, travel sensors for controllers and many other items.

Customized solutions

Innovation and standard solutions in combination

GEMÜ has an extensive range of products. Nevertheless, there are times when a specific solution has to be found.

That is why, alongside our wide range of standard products, we also offer specially developed solutions and bespoke valve concepts for our customers and sales prospects. Whether it concerns a modification or a new development, our modular system with proven standard modules allows plenty of flexibility for individual design possibilities.

When searching for reliable plant components, our engineers begin by drawing on our tried and tested standard modules, even for new developments. Wherever possible, they combine new technologies with these proven components. This is cost-effective and also guarantees safety.

You will benefit from:

- More than 50 years of experience and engineering expertise in the field of customized valve designs
- Extensive competence in industrial plant and process engineering
- GEMÜ's wide range of products and modular system
- Maximum reliability and performance in manufacturing, even for new assignments



Space-saving and multi-functional Multi-port valve blocks for industrial engineering

GEMÜ valve blocks are an example of customized valve design and flexible design.

Multi-port valves or multi-port valve blocks unite a variety of functions in the smallest of spaces thanks to their individual design, such as:

- Mixing
- Dividing
- Channelling
- Draining and feeding of various media

They can also fulfil safety functions, double shut-off (double block and bleed), cross connections and control functions. These individual functions serve very specific purposes in individual situations, such as the taking of samples, the distribution of chemicals, the connection of cleaning media (CIP) and ensuring a minimum flow rate. There are also numerous more complex functions in connection with process automation. Pressure or temperature sensors can

be integrated for example. Intelligently designed, multi-port valve blocks can be developed into compact system components with a high degree of functionality.

Solutions are developed together with the customer

GEMÜ supports its customers at the planning phase with ideas and initial drafts. The drafts are laid out for design purposes in the 3D CAD system, agreed in close cooperation with the customer and finally processed in a state-of-the-art efficient machining centre. Every day, our design centre turns out new customized block designs.

Whatever you envisage or whatever we work out together with you – as long as it is technically feasible, we will make it a reality at GEMÜ.

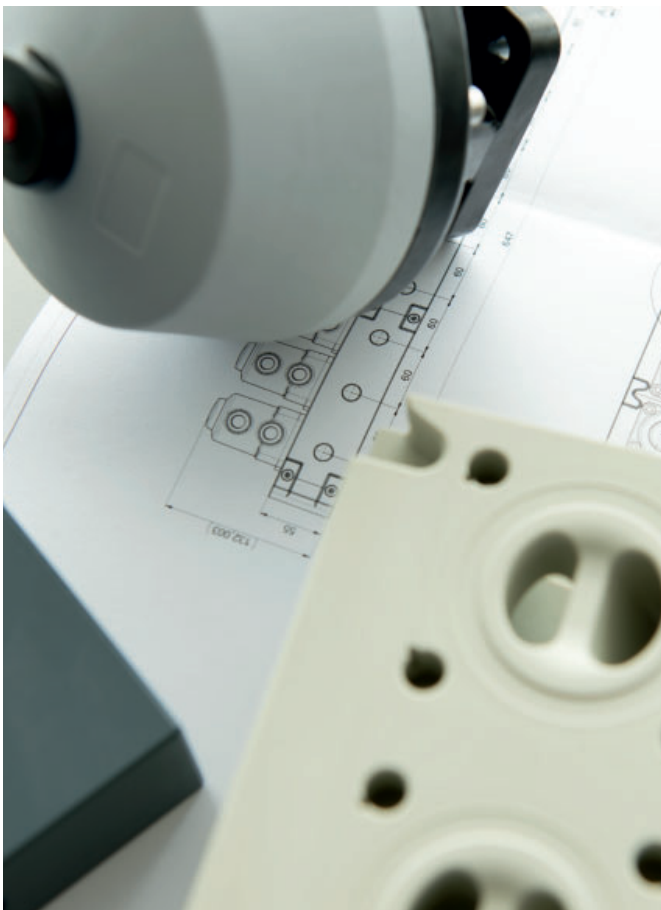

It's all about the right service

Every application is different and therefore sets very different requirements for the measurement and control systems. In addition, numerous valve designs are available to implement complex process sequences. It's easy to lose sight of everything.

To ensure that our customers can focus on the big picture, we provide detailed support on a case-by-case basis. Namely, in selecting the right components.

Taking into account all relevant operating parameters, such as pressure, temperature and the properties of the medium to be controlled, we always develop and calculate the right configuration. Our specialized and experienced team of applications technicians and engineers ensures that precisely the right valves for the particular service life

and performance features are selected. And the focus is always on creating the optimal plant for our customers' work processes.

This is supplemented with a multi-layered training system. Our experienced trainers not only teach basic knowledge, but also expert knowledge about valves and applications. Whether at GEMÜ's headquarters or directly at the customer's premises as an in-house training course.

Furthermore, GEMÜ supports its customers with repair work, commissioning and troubleshooting, if required. A dedicated repair and service team is available for these tasks.



Process reliability due to tested quality

If you value high quality, in-house quality assurance is a must. That's why the GEMÜ test laboratory is equipped with state-of-the-art measuring equipment to allow comprehensive testing of our products. This also enables us to test highly customized designs in order to determine the parameters for the most economically efficient operation.

At GEMÜ, we only use carefully selected materials and our quality management system ensures continuous monitoring. External institutes also testify to this quality.



GEMÜ CONEXO

Electronic identification and paperless maintenance

The interaction between valve components equipped with an RFID chip and the corresponding IT infrastructure actively increases process reliability.



Thanks to serialization, every valve – whether from GEMÜ or a third party provider – and every relevant valve component such as the body, actuator or diaphragm, can be clearly traced and read at any time using the RFID reader – the CONEXO pen. The CONEXO app, which can be installed on mobile devices, not only facilitates and improves the "installation qualification" process, but also makes the

maintenance process much more transparent and easier to document. The app actively guides maintenance technicians through the maintenance schedule and directly provides them with all the information assigned to the valve, such as test reports, testing documentation and maintenance histories. The CONEXO portal acts as a central element, helping to collect, manage and process data.

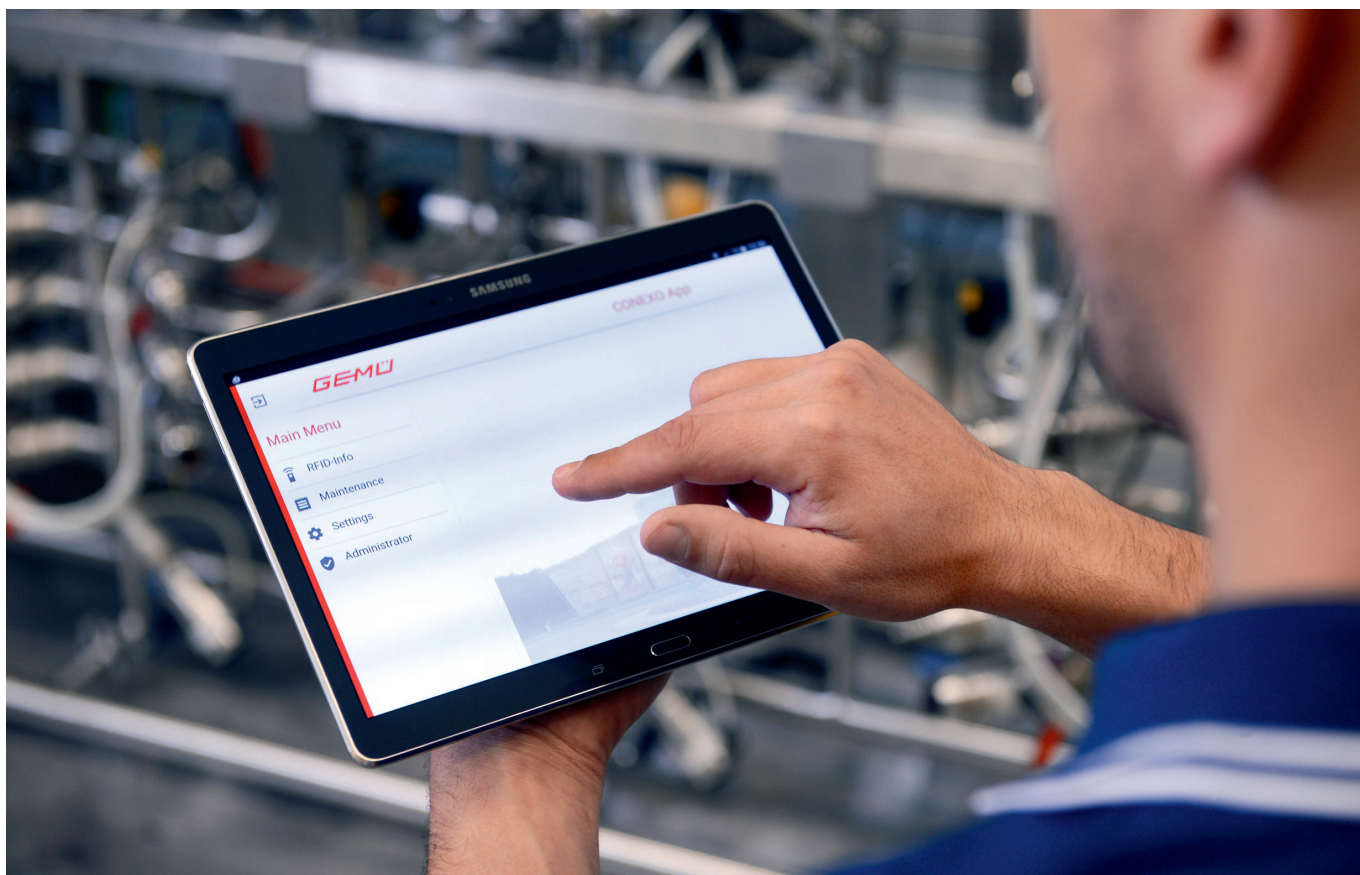

Clear, traceable identification by means of an RFID chip

Relevant system components

Features and descriptions

CONEXO pen

- Mobile RFID reading device in the form of a pen
- Coupling to mobile end devices possible
- Styluses for touchscreens (smartphone and tablet)
- UHF signal processing



CONEXO app

- Identification and electronic inventory of components
- Simple, paperless, guided maintenance documentation
- Clear allocation of certificates to the respective components and provision of important documentation that can be called up in the plant itself
- Multilingual (German, English, French, Japanese)
- Compatible with Android and iOS mobile devices – online and offline



CONEXO portal

- Central management unit
- Quick and easy access to components and location documents
- Electronic inventory of the locations and the components assigned to them
- Provision of and access to important documentation and certificates
- Creation of maintenance tasks
- Developed in accordance with GAMP 5 regulations
- Multilingual (German, English, French, Japanese)
- Cloud hosting available upon request

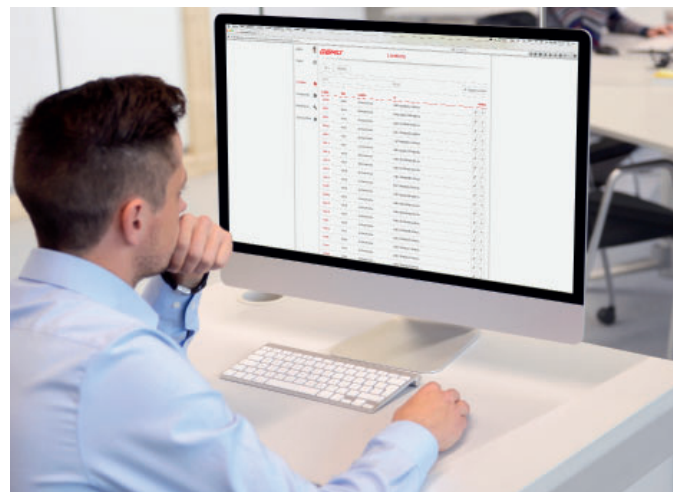

Product overview



	Design	Metal butterfly valves	Plastic butterfly valves
	GEMÜ types	481, 487, 488, 491, 497, 498	410, 417, 423, D451, D457, D458
	Pressure range	0 to 16 bar	0 to 10 bar
	Temperature	max. 200 °C	max. 90 °C
	Nominal size	DN 25 to 1600	DN 15 to 300
Actuator	Manual	•	•
	Pneumatic	•	•
	Motorized	•	•
Housing/body material	Stainless steel	•	
	Cast iron		
	Cast iron with hard rubber lining		
	SG iron	•	
	SG iron with PFA, PP lining		
	Brass		
	Cast bronze		
	ABS		
	PVDF		
	PP		•
PVC		•	
Seal material	PTFE	•	
	EPDM	•	•
	NBR	•	
	Steel		
	TFM	•	
	Silicone	•	
	CR		
	NR (natural rubber)		
	IIR (butyl rubber)		
	FPM	•	•
Disc material	Stainless steel	•	
	Cast steel	•	
	SG iron	•	
	Titanium	•	
	Hastelloy	•	
	PFA encapsulated	•	
	PVDF		•
	PVC		•
	PP		•
	CF8M	•	
	Super Duplex	•	
Connection	Flange	•	•
	Clamp		
	Welding/solvent cement spigot		
	Threaded socket		
	Union end		•

Worldwide presence

AUSTRALIA

GEMÜ Australia Pty. Ltd
Unit 4 - 8/10 Yandina Road
West Gosford, NSW 2250
Phone: +61-2-43 23 44 93
Fax: +61-2-43 23 44 96
mail@gemu.com.au

AUSTRIA

GEMÜ GmbH
Europaring F15 401
2345 Brunn am Gebirge
Phone: +43 22-36 30 43 45-0
Fax: +43 22-36 30 43 45-31
info@gemue.at

BELGIUM

GEMÜ Valves bvba/sprl
Koning Albert 1 laan, 64
1780 Wemmel
Phone: +32 2 702 09 00
Fax: +32 2 705 55 03
info@gemue.be

BRAZIL / SOUTH AMERICA

GEMÜ Indústria de Produtos Plásticos e Metalúrgicos Ltda.
Rue Marechal Hermes, 1141
83.065-000 São José dos Pinhais, Paraná
Phone: +55-41-33 82 24 25
Fax: +55-41-33 82 35 31
gemu@gemue.com.br

CANADA

GEMÜ Valves Canada Inc.
2572 Daniel-Johnson Boulevard
Laval, Quebec
H7T 2R8
Phone: +1-450-902-2690
Fax: +1-404-3 44 4003
info@gemu.com

CHINA

GEMÜ Valves (China) Co., Ltd
No.518, North Hengshahe Road
Minhang District, 201108
Shanghai
Phone: +86-21-2409 9878
info@gemue.com.cn

DENMARK

GEMÜ ApS
Industriparken 16-18
2750 Ballerup
Phone: +45 70 222 516
Fax: +45 70 222 518
info@gemue.dk

FRANCE

GEMÜ S.A.S
1 Rue Jean Bugatti
CS 99308 Duppigheim
67129 Molsheim Cedex
Phone: +33-3 88 48 21 00
Fax: +33-3 88 49 12 49
info@gemu.fr

INTERCARAT

1 Rue Jean Bugatti
CS 99308 Duppigheim
67129 Molsheim Cedex
Phone: +33-3 88 48 21 00
Fax: +33-3 88 49 14 82
sales@intercarat.com

GERMANY

GEMÜ Gebr. Müller GmbH & Co. KG
Fritz-Müller-Straße 6 - 8
74653 Ingelfingen-Criesbach
Postfach 30
74665 Ingelfingen-Criesbach

Phone: +49 (0)7940-12 30
Fax: +49 (0)7940-12 31 92
(Domestic)
Fax: +49 (0)7940-12 32 24
(Export)
info@gemue.de

GREAT BRITAIN / UK

GEMÜ Valves Ltd.
10 Olympic Way
Birchwood, Warrington
WA2 0YL
Phone: +44-19 25-82 40 44
Fax: +44-19 25-82 80 02
info@gemu.co.uk

HONG KONG

GEMÜ (Hong Kong) Co., Ltd.
Room 2015, Tower B,
Regent Centre,
70 TA Chuen Ping Street
Kwai Chung, N.T., Hong Kong
P.R. China
Phone: +852 6873 8280
Fax: +852 6873 8280
info@gemue.com.cn

INDIA

GEMÜ India
Representative Office
301, K.B. Complex, Rambaug,
L.G.Hospital Road, Maninagar,
Ahmedabad-380 008
Phone: +91-79-25450438
+91-79-25450440
Fax: +91-79-25450439
sales@gemu.in

INDONESIA

GEMÜ Valves Pte Ltd
(Indonesia Representative Office)
Rukan Mangga Dua Square
Block F17, 2nd Floor
Jl. Gunung Sahari Raya No. 1
Jakarta Utara 14420
Indonesia
Phone: +62 (21) - 6231 0035
Fax +62 (21) - 2907 4643
info@gemu.co.id

IRELAND

GEMÜ Ireland Ltd
15 Eastgate Drive
Eastgate Business Park
Little Island
Co. Cork
Phone: +353 (0)21 4232023
Fax: +353 (0)21 4232024
info@gemu.ie

ITALY

GEMÜ S.r.l.
Via Giovanni Gentile, 3
20157 Milano
Phone: +39-02-40044080
Fax: +39-02-40044081
info@gemue.it

JAPAN

GEMÜ Japan Co., Ltd.
2-5-6, Aoi, Higashi-ku,
Nagoya, Aichi, 461-0004
Phone: +81-52-936-2311
Fax: +81-52-936-2312
info@gemu.jp

MALAYSIA

GEMÜ VALVES PTE LTD
(Malaysia Representative Office)
D-8-09, Block D, No. 2A
Jalan PJU 1A/7A
Oasis Square, Oasis Damansara
47301 Petaling Jaya
Selangor Darul Ehsan
Phone: +(603)- 7832 7640
Fax: +(603)- 7832 7649
info@gemu.com.sg

MEXICO

GEMÜ Valvulas S.A. de C.V.
German Centre,
Av. Santa Fe No. 170 – OF. 5-1-05
Col. Lomas de Santa Fe,
Del. Alvaro Obregon
01210 Mexico, D.F.
Phone: +52 55 7090 4161
+52 55 7090 4179

RUSSIA

OOO „GEMÜ GmbH“
Uliza Shipilovskaya, 28A
115563, Moskau
Phone: +7(495) 662-58-35
Fax: +7(495) 662-58-35
info@gemue.ru

SINGAPORE

GEMÜ Valves PTE. LTD.
25 International Business Park
German Centre #03-73/75
Singapore 609916
Phone: +65-65 62 76 40
Fax: +65-65 62 76 49
info@gemu.com.sg

SOUTH AFRICA

GEMÜ Valves Africa Pty. Ltd
Stand 379
Northlands Business Park,
Hoogland Ext 45
Northriding, Randburg
Phone: +27(0)11 462 7795
Fax: +27(0)11 462 4226
office@gemue.co.za

SWEDEN

GEMÜ Armatur AB
Box 5
437 21 Lindome
Phone: +46-31-99 65 00
Fax: +46-31-99 65 20
order@gemu.se

SWITZERLAND

GEMÜ GmbH
Seetalstr. 210
6032 Emmen
Phone: +41-41-7 99 05 05
Fax: +41-41-7 99 05 85
info@gemue.ch

GEMÜ Vertriebs AG
Lettenstrasse 3
6343 Rotkreuz
Phone: +41-41-7 99 05 55
Fax: +41-41-7 99 05 85
vertriebsag@gemue.ch

TAIWAN

GEMÜ Taiwan Ltd.
9F.-5, No.8, Ziqiang S. Rd.
Zhubei City
Hsinchu County 302,
Taiwan (R.O.C.)
Phone: +886-3-550-7265
Fax: +886-3-550-7201
office@gemue.tw

UNITED STATES

GEMÜ Valves Inc.
3800 Camp Creek Parkway
Suite 120, Building 2600
Atlanta, Georgia 30331
Phone: +1-678-5 53 34 00
Fax: +1-404-3 44 93 50
info@gemu.com

In addition to these subsidiaries, GEMÜ has a global partner network.

Contact details:

https://www.gemu-group.com/en_GB/kontakte/



 GEMÜ manufacturing site

 GEMÜ subsidiary

GEMÜ Gebr. Müller Apparatebau GmbH & Co. KG
Fritz-Müller-Straße 6-8 · D-74653 Ingelfingen-Criesbach
Phone +49 (0)7940 123-0 · info@gemu.de

www.gemu-group.com